

**AGENDA**  
**SOUTH HAVEN CHARTER TOWNSHIP**  
**April 8, 2026**

1. Call to Order
2. Pledge of Allegiance
3. Approval of Minutes of March 11, 2026
4. Correspondence
5. Public Comments, Audience Members are allowed 3 minutes to discuss items not on the Agenda (5 minutes for groups)
6. Approval of Agenda
  
7. UNFINISHED BUSINESS
  - A) Affordable Housing Updates
  - B) Short Term Rental Updates
  - C)
  
8. NEW BUSINESS
  - A) Land Division Act Amendment
  - B) Lawn Maintenance
  - C) Resolution 26-08 Introduce Ord 173 to Amend 167 – Sunset Grove
  - D) Resolution 26-09 Introduce Ord 174 to Amend 172 – Lighthouse Ridge
  - E) Resolution 26-10 Road Millage Ballot Language Approval
  - F) Resolution 26-11 Support Adoption of Brownsfield Plan – SOHA Drift Lofts
  - G)
  - H)
  
9. REPORTS
  - Airport
  - Building/Electrical/Mechanical
  - Building Committee
  - Fire/Ambulance
  - Library
  - Park Committee
  - Planning Commission
  - Roads
  - Senior Services
  - Water/Sewer Authority
  - Zoning Board of Appeals
  
10. TREASURER’S REPORT
  
11. BOARD COMMENTS
  
12. ADJOURNMENT

**SOUTH HAVEN CHARTER TOWNSHIP  
MINUTES OF REGULAR MEETING  
WEDNESDAY, MARCH 11, 2026**

**Present:** Stein, Poole, Wiatrowski, Fisher, Bertorelli and Lewandowski

**Absent:** DeGrandchamp

**Meeting was called to order** by Supervisor Stein at 7:30 p.m.

**Motion by Wiatrowski**, supported by Poole, to approve the Minutes of the February 11, 2026 Regular Meeting as presented. All voted in favor. Motion carried.

**Captain Brian Montgomery** was in attendance and gave a report for SHAES. Chief Adam DeBoer reported for SHPD and **Gayle Gladney** reported for the Van Buren County Commission. **Dave Rozman** from Habitat for Humanity spoke about the Home Repair Grants in Van Buren County.

**Motion by Lewandowski**, supported by Fisher, to approve the Agenda. All voted in favor. Motion carried.

**Supervisor Stein** pointed out that several Affordable Housing items were in New Business. Clerk Bertorelli reported that there have been six applications submitted for STR and Trustee Wiatrowski reported that there were some clarifications he would like to make to the application and both hoped that Granicus is ready to start handling more of the paperwork.

**Dave Rozman** from Habitat for Humanity spoke about doing a future affordable housing project in South Haven Township. Supervisor Stein reported that the township owns 7 acres that could be used for future development. He also reported that zoning changes that are in the works could help facilitate future developments. He also discussed ways to keep properties affordable in this type of development.

**Motion by Poole**, supported by Wiatrowski, to support the Township Supervisor in pursuing an affordable housing plan at this location. All voted in favor. Motion carried.

**Motion by Lewandowski**, supported by Fisher, to adopt Resolution 26-05 regarding LED traffic control devices and allow installation of solar lit traffic signs on the corner of 72<sup>nd</sup> Street and 16<sup>th</sup> Avenue. All voted in favor by roll call vote. Motion carried.

**Dawn Hinz** was in attendance to discuss the need for road usage during a Multisport Event being held at Lake Arvesta. On May 15<sup>th</sup> a portion of 8<sup>th</sup> Avenue will need to be used for a running event from 9 to 11 a.m.

**Motion by Wiatrowski**, supported by Poole, to allow, by Resolution the usage of 8<sup>th</sup> Avenue during the hours of 9 a.m. to 11 a.m. on May 15, 2026, for a sporting event. Event planners were directed to notify residents of the event and it was

recommended they use door tags, and to direct SHPD to participate to keep everyone safe. All voted yes by roll call vote. Motion carried.

**Motion by Wiatrowski**, supported by Bertorelli, to create a letter of support and send copies to all state government representation opposing the State House Bills circulating to remove local control of zoning. All voted in favor. Motion carried.

**Board members** received a packet regarding Land Division Amendments from the Zoning Administrator. Members wished to spend more time reviewing the material and postpone any action until the next board meeting.

**Clerk Bertorelli** reported that South Haven Township received the Marijuana Excise Tax revenue. It was around \$162,000.00.

**Lawn Maintenance** contract was postponed until the April Board Meeting.

**Brennon Davis from Wallick Group** was in attendance to talk about the Lighthouse Ridge project and the need to reduce the Pilot amount from 4% to 1%. Supervisor Stein presented the economic impact of this request. Currently the empty fields yields about \$40.00 a year in general tax revenue in the township. With the increase in residents we will get around \$109.00 a year per resident in State Constitutional Revenue Sharing along with the 1% Pilot revenue.

**Motion by Poole**, supported by Lewandowski, to amend the Pilot from 4% to 1% for Lighthouse Ridge and to direct the township attorney to facilitate these changes. All voted in favor. Motion carried.

**Diane Rigozzi** of Van Buren Senior Services was in attendance to present a Donation Agreement document that needed approval for the Sunset Grove housing project.

**Motion by Wiatrowski**, supported by Fisher, to approve the Donation Agreement. All voted yes by roll call vote. Motion carried.

**Motion by Poole**, supported by Wiatrowski, to adopt Resolution 26-06 to introduce Ordinance 173 amending Ordinance 172 to change the language on that Ordinance for the PUD and Rezoning of Lighthouse Apartments. All voted in favor by roll call vote. Motion carried.

**Reports** from various committees and authorities were received. W.C. Askew was in attendance for the Road Commission. Diane Rigozzi reported for Senior Services.

**Motion by Fisher**, supported by Lewandowski, to approve payment of anticipated bills in the amount of \$91,902.42. All voted in favor by roll call vote. Motion carried.

**Meeting adjourned** at 8:58 p.m.

---

Brenda Bertorelli, Clerk

---

Ross Stein, Supervisor





# Corewell Health Southwest Michigan



Natalie Baggio, DNP, MBA, BSN, RN

**PRESIDENT, COREWELL HEALTH SOUTHWEST MICHIGAN**



**Natalie Baggio, DNP, MBA, BSN, RN**  
President, Corewell Health Southwest  
Michigan





## Mission

Improve health, instill humanity and inspire hope.

---

## Vision

A future where health is simple, affordable, equitable and exceptional.

---

## Values

Compassion. Collaboration.  
Clarity. Curiosity. Courage.

# Corewell Health South 2026 Strategic Initiatives



Ambulatory  
Growth



Service Line  
Growth



Community  
Impact



Foundational  
Investment



# Corewell Health South Region Markets

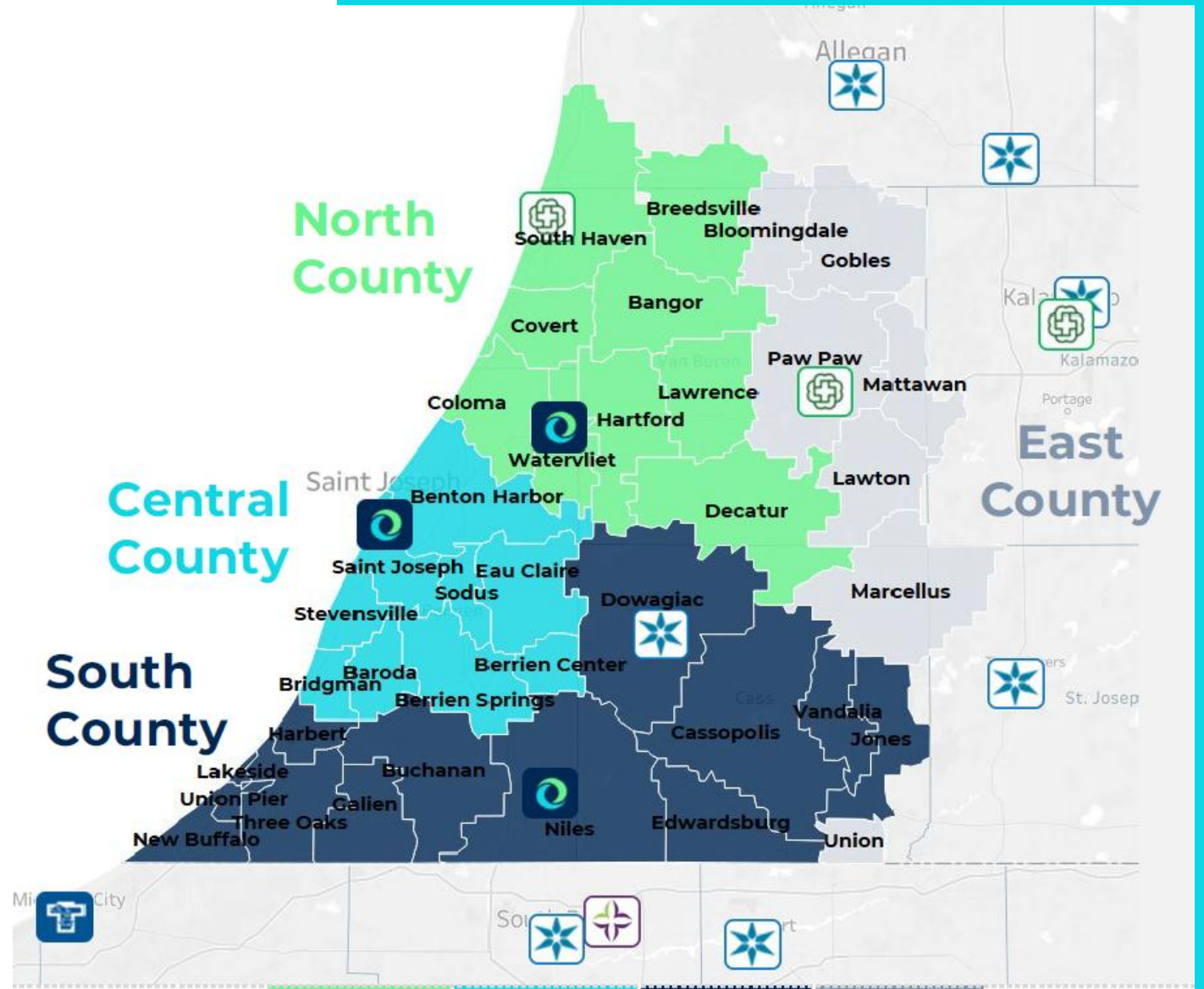

	North	Central	South	East	Overall
Population	54,302	89,244	95,254	46,536	285,336

# Watervliet Initiatives



# South Haven Urgent Care

Integrated Care Center

71989 County Road 388,  
South Haven, MI 49090

## Design Update

- Square Footage: 15,000
- Signed Purchase Agreement
- Tentative Construction Start: July 2026

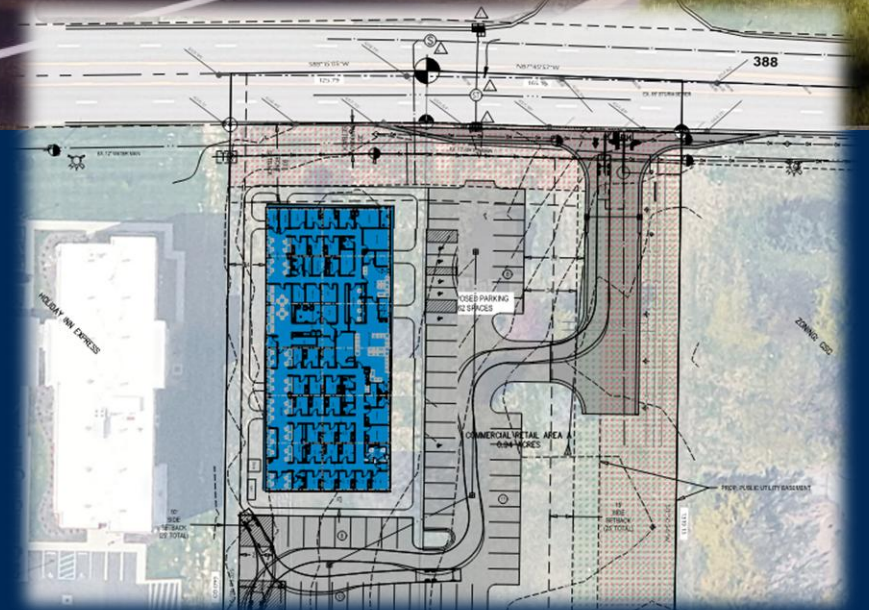

---

**Natalie Baggio, DNP, MBA, BSN, RN**

President, Corewell Health Southwest Michigan

[Natalie.baggio@corewellhealth.org](mailto:Natalie.baggio@corewellhealth.org)



1210 Phoenix Street • Suite #4 • South Haven, MI 49090  
 Email: angie@morenoandsonsinc.com  
 Office: 269-767-0394 • Jamie: 269-759-3229

**BILLING ADDRESS:**  
 South Haven Charter Township  
 09761 Blue Star Highway  
 South Haven, MI 49090

**SERVICE ADDRESS:**  
 Township Hall  
 09761 Blue Star Highway  
 South Haven, MI 49090

### 2026 Landscape Maintenance Contract

Home# (____)	Cell# (____)	Email: _____
--------------	--------------	--------------

Mark an **X** next to the services you would like preformed

Maintenance Services	QT Y	What's Included	Price
<b>MOWING</b>			
<input type="checkbox"/> Weekly Mowing	<b>26</b>	Weekly mowing, string trimming, edging (once every 3 weeks), blowing walks	\$180.00
<input type="checkbox"/> Bi-Weekly Mowing	<b>13</b>	Every other week mowing, string trimming, edging (once a month), blowing walks	
<b>YARD CLEAN-UP</b>			
<input type="checkbox"/> Spring Clean-Up	<b>1</b>	Clean yard and beds of leaves/debris, cut back ornamental grasses. Haul away leaves/debris after clean-up is complete	\$350.00
<input type="checkbox"/> Fall Clean-Up	<b>1</b>	Clean yard and beds of leaves/debris, cut back perennials. Haul away leaves/debris after clean-up is complete	\$450.00
<b>LANDSCAPE CARE</b>			
<input type="checkbox"/> Landscape Mulch	<b>1</b>	Installing new mulch in all landscape beds and redefining bed lines	\$200.00
<input type="checkbox"/> Mole Control	<b>1</b>	Applied in spring	\$95.00
<input type="checkbox"/> Grub Preventative	<b>1</b>	Applied in spring / early summer	\$145.00
<input type="checkbox"/> Fertilization	<b>1</b>	Fertilize and weed control applied to lawn	\$740.00

<b>ACCEPTED BY (SIGNATURE):</b> _____	<b>DATE:</b> _____
---------------------------------------	--------------------

\*\*\*The above prices and services are hereby accepted. Moreno and Sons Inc. is authorized to perform work as specified. Either party may cancel with 30 day written notice. If payment is not received within 30 days, finance charges may be assessed each month. If payment is not received within 60 days of due date, the account will be put on hold until paid.



1210 Phoenix Street • Suite #4 • South Haven, MI 49090  
 Email: angie@morenoandsonsinc.com  
 Office: 269-767-0394 • Jamie: 269-759-3229

**BILLING ADDRESS:**  
 South Haven Charter Township  
 09761 Blue Star Highway  
 South Haven, MI 49090

**SERVICE ADDRESS:**  
 Deerlick Park  
 76773 13th Ave  
 South Haven, MI 49090

### 2026 Landscape Maintenance Contract

Home# (____) _____	Cell# (____) _____	Email: _____
--------------------	--------------------	--------------

Mark an X next to the services you would like preformed

Maintenance Services	QTY	What's Included	Price
<b>MOWING</b>			
<input type="checkbox"/> Weekly Mowing	<b>26</b>	Weekly mowing, string trimming, edging (once every 3 weeks), blowing walks	\$82.00
<input type="checkbox"/> Bi-Weekly Mowing	<b>13</b>	Every other week mowing, string trimming, edging (once a month), blowing walks	
<b>YARD CLEAN-UP</b>			
<input type="checkbox"/> Spring Clean-Up	<b>1</b>	Clean yard and beds of leaves/debris, cut back ornamental grasses. Haul away leaves/debris after clean-up is complete	\$475.00
<b>LANDSCAPE CARE</b>			
<input type="checkbox"/> Landscape Mulch	<b>1</b>	Installing new mulch in all landscape beds and redefining bed lines	\$1,050.00
<b>ACCEPTED BY (SIGNATURE):</b>		<b>DATE:</b>	

\*\*\*The above prices and services are hereby accepted. Moreno and Sons Inc. is authorized to perform work as specified. Either party may cancel with 30 day written notice. If payment is not received within 30 days, finance charges may be assessed each month. If payment is not received within 60 days of due date, the account will be put on hold until paid.

**CHARTER TOWNSHIP OF SOUTH HAVEN  
RESOLUTION NO. 26-08**

**RESOLUTION TO INTRODUCE  
AN ORDINANCE TO AMEND ORDINANCE TO PROVIDE FOR  
A PAYMENT IN LIEU OF TAXES**

At a meeting of the Board of Trustees of the Charter Township of South Haven ("Township"), Van Buren County, Michigan, held at the Township Hall in said Township on the 8th day of April, 2026 at 7:30 p.m.

PRESENT: \_\_\_\_\_

\_\_\_\_\_

ABSENT: \_\_\_\_\_

\_\_\_\_\_

The following Resolution was offered by \_\_\_\_\_ and seconded by \_\_\_\_\_.

WHEREAS, South Haven Charter Township wishes to encourage developers to build affordable housing by accepting a service charge or payment in lieu of property taxes (a "PILOT"), as authorized by the State Housing Development Authority Act of 1966, 1966 PA 356, MCL 125.1401 et seq., as amended; and

WHEREAS, the Township adopted an Ordinance creating a PILOT for the proposed Sunset Grove Housing Development (the "Ordinance"); and

WHEREAS, the Township desires to amend the PILOT Ordinance for Sunset Grove to add the Authority as a third-party beneficiary to the Township's contract with Samaritas Affordable Living Sunset Grove LDHA LP.; and

WHEREAS, Section 20 of the Michigan Charter Township Act, Act 359 of 1947, MCL 42.1 et seq, as amended ("Act") requires each proposed ordinance be introduced in written or

printed form, identified by a number and short title and, following introduction of the proposed ordinance, requires the Clerk to publish the proposed ordinance as provided in the Act.

NOW, THEREFORE, the Township Board of the Charter Township of South Haven, resolves as follows:

1. The Township hereby introduces Ordinance No.173, An Ordinance to Amend Ordinance to Provide For A Payment In Lieu of Taxes, attached as **Exhibit A**.

2. The Township Board will consider adopting the Ordinance at a meeting on May 13, 2026, at 7:30 p.m.

3. Pursuant to Section 20 of the Act, the Clerk is directed to publish the Ordinance in accordance with Section 8 of the Act by posting the Ordinance in the office of the Clerk and on the Township's web site. The Clerk is further directed to publish notice of posting in a form substantially conforming to that attached as **Exhibit B** to this resolution describing the purpose of the Ordinance and that the Ordinance is posted in the office of the Clerk, on the Township's web site and in a newspaper of general circulation in the Township within seven (7) days of the posting.

4. A copy of the Ordinance shall be available for examination at the office of the Clerk and copies may be provided for a reasonable charge.

5. Any and all resolutions that are in conflict with this Resolution are hereby repealed to the extent necessary to give this Resolution full force and effect.

YEAS: \_\_\_\_\_

NAYS: \_\_\_\_\_

THE RESOLUTION WAS DECLARED ADOPTED.

STATE OF MICHIGAN )

) ss.  
COUNTY OF VAN BUREN )

I, Brenda Bertorelli, Township Clerk of the Charter Township of South Haven, hereby certify this to be a true and complete copy of Resolution No. 26-08, duly adopted at a meeting of the Township Board held on the 8th day of April, 2026 at 7:30 p.m.

---

Brenda Bertorelli, Township Clerk

**EXHIBIT A**

**SOUTH HAVEN TOWNSHIP  
ORDINANCE NO. 173**

**AN ORDINANCE TO AMEND ORDINANCE 167 TO PROVIDE FOR  
A PAYMENT IN LIEU OF TAXES**

**THE TOWNSHIP OF SOUTH HAVEN ORDAINS:**

**Section 1. Amendment of Section 6**

Section 6 of Ordinance is hereby amended to read, in its entirety, as follows:

To the extent permitted by law and notwithstanding the provisions of Section 15(a)(5) of the Act to the contrary, a contract between the Charter Township of South Haven and the Sponsor with the Authority as third party beneficiary under the contract, to provide tax exemption and accept payments in lieu of taxes, as previously described, is effectuated by enactment of this Ordinance.

**Section 2. Severability.**

The various sections and provisions of this Ordinance shall be deemed to be severable, and should any section or provision of this Ordinance be declared by any court of competent jurisdiction to be unconstitutional or invalid, the same shall not affect the validity of the Ordinance as a whole or any section or provision of this Ordinance other than the section or provision so declared to be unconstitutional or invalid.

**Section 3. Inconsistent Ordinances.**

All other ordinances inconsistent with the provisions of this Ordinance are hereby repealed only to the extent necessary to give this Ordinance full force and effect.

**Section 4. Effective Date**

This Ordinance shall take effect immediately after publication.

\_\_\_\_\_  
Township Clerk

Dated: \_\_\_\_\_

**CHARTER TOWNSHIP OF SOUTH HAVEN**

**NOTICE OF POSTING OF PROPOSED ORDINANCE NO. 173  
AN ORDINANCE TO AMEND ORDINANCE TO PROVIDE FOR  
A PAYMENT IN LIEU OF TAXES**

**PLEASE TAKE NOTICE** that at its meeting on April 8, 2026, the Township Board received a proposed ordinance entitled “An Ordinance To Amend Ordinance 167 To Provide For A Payment In Lieu Of Taxes,” which will be considered for adoption on **May 13, 2026, at 7:30 p.m.**, at a meeting of the Township Board at the Township Hall, 09761 Blue Star Memorial Hwy, South Haven, MI 49090. The proposed ordinance would amend PILOT Ordinance for Sunset Grove to add the Authority as a third-party beneficiary to the Township’s contract with Samaritas Affordable Living Sunset Grove LDHA LP.

The proposed ordinance is available in its entirety for public inspection. The proposed ordinance is posted at the office of the Township Clerk, 09761 Blue Star Memorial Hwy, South Haven, MI 49090 and on the website of the Charter Township of South Haven, <http://www.southhaventwp.com>.

Brenda Bertorelli, Clerk  
South Haven Township Hall  
09761 Blue Star Memorial Hwy  
South Haven, MI 49090  
(269) 637-3305

**CHARTER TOWNSHIP OF SOUTH HAVEN  
RESOLUTION NO. 26-09**

**RESOLUTION TO INTRODUCE  
AN ORDINANCE 174 TO AMEND ORDINANCE 172 TO PROVIDE FOR  
A SERVICE CHARGE IN LIEU OF TAXES FOR DWELLING UNITS  
FOR LOW INCOME PERSONS OR FAMILIES (LIGHTHOUSE RIDGE  
APARTMENTS)**

At a meeting of the Board of Trustees of the Charter Township of South Haven ("Township"), Van Buren County, Michigan, held at the Township Hall in said Township on the 8th day of April, 2026 at 7:30 p.m.

PRESENT: \_\_\_\_\_  
\_\_\_\_\_

ABSENT: \_\_\_\_\_  
\_\_\_\_\_

The following Resolution was offered by \_\_\_\_\_ and seconded by \_\_\_\_\_.

WHEREAS, South Haven Charter Township wishes to encourage developers to build affordable housing by accepting a service charge or payment in lieu of property taxes (a "PILOT"), as authorized by the State Housing Development Authority Act of 1966, 1966 PA 356, MCL 125.1401 et seq., as amended; and

WHEREAS, the Township adopted an Ordinance creating a PILOT for the proposed Lighthouse Ridge Apartments (the "Ordinance"); and

WHEREAS, the Township desires to amend the Ordinance to change the annual service charger from 4% to 1%; and

WHEREAS, Section 20 of the Michigan Charter Township Act, Act 359 of 1947, MCL 42.1 et seq, as amended ("Act") requires each proposed ordinance be introduced in written or

printed form, identified by a number and short title and, following introduction of the proposed ordinance, requires the Clerk to publish the proposed ordinance as provided in the Act.

NOW, THEREFORE, the Township Board of the Charter Township of South Haven, resolves as follows:

1. The Township hereby introduces Ordinance No. 174, An Ordinance to Amend Ordinance 172 to Provide For A Service Charge In Lieu of Taxes for Dwelling Units for Low Income Persons and Families (Lighthouse Ridge Apartments), attached as **Exhibit A**.

2. The Township Board will consider adopting the Ordinance at a meeting on May 13, 2026, at 7:30 p.m.

3. Pursuant to Section 20 of the Act, the Clerk is directed to publish the Ordinance in accordance with Section 8 of the Act by posting the Ordinance in the office of the Clerk and on the Township's web site. The Clerk is further directed to publish notice of posting in a form substantially conforming to that attached as **Exhibit B** to this resolution describing the purpose of the Ordinance and that the Ordinance is posted in the office of the Clerk, on the Township's web site and in a newspaper of general circulation in the Township within seven (7) days of the posting.

4. A copy of the Ordinance shall be available for examination at the office of the Clerk and copies may be provided for a reasonable charge.

5. Any and all resolutions that are in conflict with this Resolution are hereby repealed to the extent necessary to give this Resolution full force and effect.

YEAS: \_\_\_\_\_

NAYS: \_\_\_\_\_

THE RESOLUTION WAS DECLARED ADOPTED.

STATE OF MICHIGAN     )  
  ) ss.  
COUNTY OF VAN BUREN )

I, Brenda Bertorelli, Township Clerk of the Charter Township of South Haven, hereby certify this to be a true and complete copy of Resolution No.26-09, duly adopted at a meeting of the Township Board held on the 8th day of April, 2026 at 7:30 p.m.

---

Brenda Bertorelli, Township Clerk

**EXHIBIT A**

**SOUTH HAVEN TOWNSHIP  
ORDINANCE NO. 174**

**ORDINANCE TO AMEND ORDINANCE TO PROVIDE FOR A SERVICE CHARGE IN  
LIEU OF TAXES FOR DWELLING UNITS FOR LOW INCOME PERSONS AND  
FAMILIES  
(LIGHTHOUSE RIDGE APARTMENTS)**

**THE TOWNSHIP OF SOUTH HAVEN ORDAINS:**

**Section 1. Amendment of Section 4**

Section 4 of Ordinance to Provide for a Service Charge in Lieu of Taxes for Dwelling Units for Low Income Persons and Families (Lighthouse Ridge Apartments) entitled “Establishment of Annual Service Charge” is hereby amended to change the annual service charge in the last sentence of the section from 4% to 1% of the Annual Shelter Rent actually collected.

**Section 2. Severability.**

The various sections and provisions of this Ordinance shall be deemed to be severable, and should any section or provision of this Ordinance be declared by any court of competent jurisdiction to be unconstitutional or invalid, the same shall not affect the validity of the Ordinance as a whole or any section or provision of this Ordinance other than the section or provision so declared to be unconstitutional or invalid.

**Section 3. Inconsistent Ordinances.**

All other ordinances inconsistent with the provisions of this Ordinance are hereby repealed only to the extent necessary to give this Ordinance full force and effect.

**Section 4. Effective Date**

This Ordinance shall take effect immediately after publication.

\_\_\_\_\_  
Township Clerk

Dated: \_\_\_\_\_

**CHARTER TOWNSHIP OF SOUTH HAVEN**

**NOTICE OF POSTING OF PROPOSED ORDINANCE NO. 174  
AN ORDINANCE TO AMEND ORDINANCE TO PROVIDE FOR  
A SERVICE CHARGE IN LIEU OF TAXES FOR DWELLING UNITS  
FOR LOW INCOME PERSONS OR FAMILIES (LIGHTHOUSE RIDGE  
APARTMENTS)**

**PLEASE TAKE NOTICE** that at its meeting on April 8, 2026, the Township Board received a proposed ordinance entitled “An Ordinance to Amend Ordinance 172 to Provide For A Service Charge In Lieu of Taxes for Dwelling Units for Low Income Persons and Families (Lighthouse Ridge Apartments),” which will be considered for adoption on **May 13, 2026, at 7:30 p.m.**, at a meeting of the Township Board at the Township Hall, 09761 Blue Star Memorial Hwy, South Haven, MI 49090. The proposed ordinance would amend the Ordinance to Provide for a Service Charge In Lieu of Taxes for Dwelling Units for Low Income Persons and Families (Lighthouse Ridge Apartments) to change the annual service charge in the last sentence of the section from 4% to 1% of the Annual Shelter Rent actually collected.

The proposed ordinance is available in its entirety for public inspection. The proposed ordinance is posted at the office of the Township Clerk, 09761 Blue Star Memorial Hwy, South Haven, MI 49090 and on the website of the Charter Township of South Haven, <http://www.southhaventwp.com>.

Brenda Bertorelli, Clerk  
South Haven Township Hall  
09761 Blue Star Memorial Hwy  
South Haven, MI 49090  
(269) 637-3305

**CHARTER TOWNSHIP OF SOUTH HAVEN**  
**RESOLUTION 26-10 TO APPROVE TOWNSHIP ROAD MILLAGE**  
**BALLOT PROPOSAL**

At a Regular meeting of the Board of Trustees of the Charter Township of South Haven ("Township"), Van Buren County, Michigan, held at the Township Hall in said Township on the 8<sup>th</sup> day of April, 2026 at 7:30 p.m.

PRESENT: \_\_\_\_\_

\_\_\_\_\_

ABSENT: \_\_\_\_\_

\_\_\_\_\_

The following Resolution was offered by \_\_\_\_\_  
\_\_\_\_\_ and seconded by \_\_\_\_\_.

WHEREAS, the Township desires voter approval to increase the tax limitation within the Township in an amount not to exceed 1.45 mills for a period of four (4) years beginning in 2026, to provide funds for constructing, preserving, improving, mowing, repairing, and maintaining roads and ditches in the Township; and

WHEREAS, the Township desires to present the millage proposal to the electors of the Township at the August 4, 2026 election; and

WHEREAS, the Township has determined that the requested millage is in the best interests of the public health, safety and welfare of the Township residents.

THEREFORE, the Township Board of the Charter Township of South Haven, Van Buren County, resolves as follows:

1. The Township Board of the Charter Township of South Haven has determined that a millage is necessary to provide funds for constructing, preserving, improving, mowing, repairing, and maintaining roads and ditches in the Township; and

2. To that end, the Township Board approves the ballot language attached as Exhibit A and certifies that the proposition attached as Exhibit A shall be submitted to a vote of the qualified electors of the Township at an election to be held on Tuesday, August 4, 2026.

3. The Township Clerk is authorized and directed to promptly submit this Resolution and the ballot language attached as Exhibit A to the Van Buren County Clerk so that the attached millage proposal may be presented to voters at the August 4, 2026 election.

4. Any resolution inconsistent with this Resolution is hereby rescinded.

ADOPTED:

YEAS: \_\_\_\_\_

NAYS: \_\_\_\_\_

STATE OF MICHIGAN                    )  
  )  
COUNTY OF VAN BUREN                )

I, the undersigned, the duly qualified and acting Township Clerk of the Charter Township of South Haven, Van Buren County, Michigan, DO HEREBY CERTIFY that the foregoing is a true and complete copy of certain proceedings taken by the Township Board of said Township at a Regular meeting held on the 8<sup>th</sup> day of April 2026.

\_\_\_\_\_  
Brenda Bertorelli, Township Clerk

**EXHIBIT A**

**CHARTER TOWNSHIP OF SOUTH HAVEN  
ROAD MILLAGE PROPOSAL**

Shall the tax limitation on all taxable property within the Charter Township of South Haven, Van Buren County, Michigan, be increased and the Township be authorized to levy a new additional millage in an amount not to exceed 1.45 mills (\$ 1.45 on each \$1,000 of taxable value) for four (4) years, 2026 to 2029 inclusive, to provide funds for constructing, preserving, improving, mowing, repairing, and maintaining roads and ditches in the Township? The estimate of the revenue the Township will collect in the first year if the millage is approved and levied in the 2026 calendar year is approximately \$373,461.

Yes

No

**SOUTH HAVEN CHARTER TOWNSHIP, MICHIGAN  
RESOLUTION 26-11  
SUPPORTING THE ADOPTION OF A BROWNFIELD PLAN  
SOHA DRIFT LOFTS, SOUTH HAVEN CHARTER TOWNSHIP, VAN BUREN COUNTY, MICHIGAN  
BY SOUTH HAVEN CHARTER TOWNSHIP  
PURSUANT TO AND IN ACCORDANCE WITH  
THE PROVISIONS OF ACT 381 OF THE PUBLIC ACTS  
OF THE STATE OF MICHIGAN OF 1996, AS AMENDED**

At a regular meeting of the South Haven Charter Township Board of Trustees, South Haven, Michigan, held at the South Haven Charter Township Hall located at 09761 Blue Star Memorial Hwy, South Haven, MI 49090, on the 8<sup>th</sup> day of April 2026 at 7:30 PM.

PRESENT: \_\_\_\_\_

\_\_\_\_\_

ABSENT: \_\_\_\_\_

MOTION BY: \_\_\_\_\_ SUPPORTED BY: \_\_\_\_\_

WHEREAS, South Haven Charter Township, pursuant to and in accordance with the provisions of the Brownfield Redevelopment Financing Act, being Act 381 of the Public Acts of the State of Michigan of 1996, as amended (the "Act"), has formally resolved to participate in the Van Buren County Brownfield Redevelopment Authority (the "Authority") and have designated that all related activities shall proceed through the Authority; and

WHEREAS, the Authority, pursuant to and in accordance with Section 13 of the Act, has reviewed and recommended for approval by the Brownfield Plan (the "Plan") attached hereto, to be carried out within South Haven Charter Township, relating to the development of property located at 73<sup>rd</sup> Street, Michigan (the "Site"), as shown in Figures 1 and 2 of the Plan and more particularly described in the legal description of the property contained within the attached Plan; and

WHEREAS, the South Haven Charter Township Board of Trustees have reviewed the Plan, and have been provided with a reasonable opportunity to express their views and recommendations regarding the Plan and in accordance with Section 14(5) of the Act; and

WHEREAS, the Van Buren County Brownfield Redevelopment Authority has passed a resolution supporting the adoption of the Plan;

WHEREAS, the South Haven Charter Township Board of Trustees have made the following determinations and findings:

1. The Plan constitutes a public purpose under the Act;
2. The Plan meets all of the requirements for a Brownfield plan set forth in Section 13 of the Act;

3. The proposed method of financing the costs of the eligible activities, as described in the Plan, was feasible and the Authority has the ability to arrange the financing;
4. The costs of the eligible activities proposed in the Plan are reasonable and necessary to carry out the purposes of the Act; and
5. The amount of captured taxable value estimated to result from the adoption of the Plan is reasonable; and

WHEREAS, as a result of the review of the Plan the South Haven Charter Township Board of Trustees concurs with the approval of the individual Plan.

NOW, THEREFORE BE IT RESOLVED THAT:

1. **Plan Support.** Pursuant to the authority vested in the South Haven Charter Township Board of Trustees, by the Act, the Plan is hereby supported in the form attached to this Resolution.
2. **Severability.** Should any section, clause, or phrase of this Resolution be declared by the courts to be invalid, the same shall not affect the validity of this Resolution as a whole nor any part thereof other than the part so declared to be invalid.
3. **Repeals.** All resolutions or parts of resolutions in conflict with any of the provisions of this Resolution are hereby repealed.

AYES: \_\_\_\_\_

NAYES: \_\_\_\_\_

ABSTAINED: \_\_\_\_\_

RESOLUTION DECLARED ADOPTED.

STATE OF MICHIGAN    )

)§

VAN BUREN COUNTY    )ss:

I, the undersigned, the fully qualified and South Haven Charter Township Clerk, State of Michigan, do hereby certify that the foregoing is a true and complete copy of a resolution adopted by the South Haven Charter Township Board of Trustees at a regular meeting held on the 8th day of April 2026, the original of which resolution is on file in my office.

IN WITNESS WHEREOF, I have hereunto set my official signature this 8<sup>th</sup> day of April 2026.

---

Brenda Bertorelli, South Haven Charter Township Clerk

# Act 381 Brownfield Plan

SoHa Drift Lofts

73rd Street

South Haven, Michigan

Van Buren County Brownfield  
Redevelopment Authority

Project No. 2501886  
March 24, 2026

## **Act 381 Brownfield Plan**

**SoHa Drift Lofts  
73rd Street  
South Haven, Michigan**

**Prepared For:  
Van Buren County Brownfield Redevelopment Authority  
Paw Paw, Michigan**

**March 24, 2026  
Project No. 2501886**

**Recommended for Approval by Brownfield Redevelopment Authority on: March 18, 2026**

**Supported by Local Unit of Government on: \_\_\_\_\_**

**Adopted by County Government on: \_\_\_\_\_**

1.0 Introduction.....1

    1.1 Proposed Redevelopment and Future Use for Each Eligible Property .....1

    1.2 Eligible Property Information .....1

2.0 Information Required by Section 13(2) of the Statute .....2

    2.1 Description of Costs to be Paid for with Tax Increment Revenues .....2

        2.1.1 Infrastructure and Safety Improvements Necessary to Support Housing .....2

        2.1.2 Brownfield Plan Preparation and Implementation .....2

        2.1.3 Contingency .....2

        2.1.4 Authority Administration Cost .....2

        2.1.5 Local Brownfield Revolving Fund .....3

    2.2 Summary of Eligible Activities.....3

    2.3 Estimate of Captured Taxable Value and Tax Increment Revenues .....3

    2.4 Method of Financing and Description of Advances Made by the Municipality .....4

    2.5 Maximum Amount of Note or Bonded Indebtedness.....4

    2.6 Duration of Brownfield Plan .....4

    2.7 Estimated Impact of Tax Increment Financing on Revenues of Taxing Jurisdictions .....4

    2.8 Legal Description, Property Map, Statement of Qualifying Characteristics, and Personal Property.4

    2.9 Estimates of Residents and Displacement of Individuals/Families .....4

    2.10 Plan for Relocation of Displaced Persons .....4

    2.11 Provisions for Relocation Costs .....4

    2.12 Strategy for Compliance with Michigan’s Relocation Assistance Law .....5

    2.13 Other Material that the Authority or Governing Body Considers Pertinent .....5

**List of Figures**

- Figure 1 – Location Map of the Eligible Property
- Figure 2 – Site Plan
- Figure 3 – Proposed Site Plan

**List of Tables**

- Table 1 – Summary of Eligible Costs
- Table 2 – Total Captured Incremental Taxes Estimates
- Table 3 – Estimated Reimbursement Schedule

**List of Appendices**

- Appendix 1 – Brownfield Plan Resolution(s)
- Appendix 2 – Development/Reimbursement Agreement
- Appendix 3 – Notice to Taxing Jurisdictions
- Appendix 4 – Notice of Public Hearing
- Appendix 5 – Relevant Sections MSHDA Partnership J Data Document
- Appendix 6 – Redevelopment Renderings

## List of Abbreviations/Acronyms

Act 381	Brownfield Redevelopment Financing Act, 1996 PA 381, as amended
Authority	Van Buren County Brownfield Redevelopment Authority
Developer	SoHa Drift Lofts LLC
LBRF	Local Brownfield Revolving Fund
MSHDA	Michigan State Housing Development Authority
PA	Public Act
TIF	tax increment financing
VBCBRA	Van Buren County Brownfield Redevelopment Authority

## 1.0 Introduction

The Van Buren County Brownfield Redevelopment Authority (Authority or VBCBRA) was established pursuant to the Brownfield Redevelopment Financing Act, Michigan Public Act (PA) of 1996, as amended (Act 381). Act 381 enables the VBCBRA to help facilitate the redevelopment of brownfields by providing economic development incentives through tax increment financing (TIF).

This Brownfield Plan includes the eligible property described in Sections 1.1 and 1.2 below and permits the use of TIF to reimburse SoHa Drift Lofts LLC (the “Developer”) for the cost of eligible activities required to redevelop the eligible property with housing. Copies of plan resolutions are provided in Appendix 1.

### 1.1 Proposed Redevelopment and Future Use for Each Eligible Property

The proposed redevelopment consists of one vacant parcel totaling approximately 10.16 acres in South Haven Township, Michigan. The Developer plans to construct 45 new market rate homes for sale, including 30 two-bedroom/ two-bath units and 15 three-bedroom/two-bath units. The proposed development activities include infrastructure and safety improvements necessary to support housing and the development of this Brownfield Plan. The total project investment is anticipated to be \$16,000,000. Construction is estimated to be initiated in 2026 and completed by the end of 2030. It is anticipated that 6 homes will be constructed in Year 1; 10 homes will be constructed in Years 2, 3, and 4 (30 homes total over the three years); and the final 9 units will be constructed in Year 5. The proposed site plan is included in Figure 3.

This project serves an important purpose in Van Buren County and South Haven Charter Township by expanding the tax base, investing significant capital into the community, and most importantly, creating new housing opportunities in a community where quality housing is needed.

### 1.2 Eligible Property Information

**Parcel ID No.:** 80-17-011-032-61  
**Address:** 73rd Steet, South Haven, Michigan 49090  
**Size:** Approximately 10.16 acres

#### **Basis of Eligibility**

The property qualifies as “eligible property” under the Brownfield Redevelopment Financing Act, 1996 PA 381, as amended (“Act 381”), on the basis of meeting the definition of a “Housing Property” in Section 2(p)(ii). Act 381 defines Housing Property, in part, as property on which one or more units of residential housing are proposed to be constructed. The project will have a total of 45 owner-occupied residential units. Maps depicting the location and layout of the property are attached as Figures 1 and 2.

According to Section 2(o)(ii), the Housing Property must be “located in a community that has identified a specific housing need and has absorption data or job growth data included in the brownfield plan.” The project meets these criteria based on the following.

#### **Specific Housing Need**

According to the Michigan State Housing Development Authority (MSHDA) Partnership J Data Documentation, South Haven Township has an owner-occupied housing vacancy rate of 0%, indicating a strong need for owner-occupied housing. Households earning over 120% of Van Buren County Area Median Income (AMI) account for one-third of the South Haven market. The proposed redevelopment will include 45 owner-occupied residential units intended to meet this large share of households in South Haven Township. Relevant housing data is provided in Appendix 5.

**Job Growth Data**

According to the Bureau of Labor Statistics, jobs in Van Buren County increased by 1,542 from 2020 to 2024. The rate of increase slowed in recent years as businesses returned to normal staffing after the pandemic, but the number of county jobs continues to increase steadily.

**Van Buren County Jobs and Labor Force Growth, 2020 to 2024**

Year	Number of Jobs
2024	20,443
2023	21,105
2022	20,551
2021	20,128
2020	18,901

U.S. Bureau of Labor Statistics, annual reports

**2.0 Information Required by Section 13(2) of the Statute**

**2.1 Description of Costs to be Paid for with Tax Increment Revenues**

This plan has been developed to reimburse eligible brownfield costs incurred by the Developer to support the revitalization of underutilized land for housing. New local tax increment revenues will be captured for reimbursement of eligible expenses based on actual available new tax increment revenue generated from the project. Base local and state taxes associated with the property will continue to be levied and distributed to local and state taxing jurisdictions. No state taxes, local debt, or special assessment taxes will be captured for reimbursement of eligible activity costs.

The total cost of eligible activities anticipated to be reimbursed to the Developer, inclusive of contingencies, is \$2,436,937. Authority administrative costs are anticipated to be \$184,887. The project’s eligible activities and estimated costs under this plan are summarized in Table 1. .

**2.1.1 Infrastructure and Safety Improvements Necessary to Support Housing**

Infrastructure and safety improvements necessary to support housing include streets and roads (\$378,222), sidewalks (\$55,730), lighting (\$75,000), storm sewers (\$192,750), electric and gas utilities (\$270,000), water mains and connections (\$417,850), curbs and gutters (\$140,000), sanitary sewer mains and connections (\$332,425), landscaping (\$99,250), and applicable soft costs such as engineering, design, survey, legal, etc. (\$149,153). The total cost of these eligible activities is anticipated to be \$2,110,380.

**2.1.2 Brownfield Plan Preparation and Implementation**

Brownfield Plan preparation and implementation is included and anticipated to be \$10,000.

**2.1.3 Contingency**

A 15% contingency is included for infrastructure and safety improvements necessary to support housing and is anticipated to be \$316,557.

**2.1.4 Authority Administration Cost**

Eligible costs incurred by the VBCBRA are included in this plan as an eligible expense . These expenses will be reimbursed with local tax increment revenues only and are anticipated to be \$184,887 over the term of the Plan.

### **2.1.5 Local Brownfield Revolving Fund**

The VBCBRA intends to capture tax increments for deposits in the LBRF for an estimated five years, or as allowed by the statute. This capture is estimated to be \$957,849,.

## **2.2 Summary of Eligible Activities**

### **Housing Development Activities**

This plan will provide reimbursement of costs for infrastructure and safety improvements necessary to support housing and Brownfield Plan preparation and implementation. These costs will be reimbursed through local tax increment revenues and are estimated to total \$2,120,380.

### **Authority Expenses**

Eligible costs incurred by the VBCBRA are included in this plan as an eligible expense . These expenses will be reimbursed with local tax increment revenues only and are estimated to total \$184,887 over the term of the Plan.

### **Contingencies**

A 15% contingency fee is included for all housing development activities to cover additional unanticipated costs during construction. These activities are anticipated to be \$316,557.

## **2.3 Estimate of Captured Taxable Value and Tax Increment Revenues**

This plan has been developed to reimburse eligible brownfield costs incurred by the Developer to support the revitalization of underutilized land for new affordable housing that meets community needs. New local tax increment revenues will be captured for reimbursement of eligible expenses based on actual available new tax increment revenue generated from the project. Base local and state taxes associated with the property will continue to be levied and distributed to local and state taxing jurisdictions. No state taxes, local debt, or special assessment taxes will be captured to reimburse eligible activity costs.

Construction will be phased over five years. Tax increment revenues have been estimated based on this construction schedule:

- 2026: Complete 6 residential units
- 2027: Complete 10 residential units
- 2028: Complete 10 residential units
- 2029: Complete 10 residential units
- 2030: Complete remaining 9 residential units

Tax increment revenue collection will start within five years of the adoption of this plan and is anticipated to begin in 2027. After completion of this project, the projected taxable value is estimated at \$8,000,000. Reimbursements will be made based on actual tax increment revenues. The estimated captured taxable value for this redevelopment by year and in aggregate for each taxing jurisdiction is depicted in tabular form (Table 2). Once eligible activities are reimbursed, the VBCBRA may capture up to five full years of tax increment or an amount not to exceed the total cost of eligible activities and deposit the revenues into the LBRF. Once the Developer is fully paid, the VBCBRA intends to place 5 full years of tax capture into the LBRF. This amount is anticipated to be \$957,849.

The total cost of eligible activities anticipated to be reimbursed to the Developer, inclusive of contingencies, is \$2,436,937. Authority administrative costs are anticipated to be \$184,887. The project's eligible activities and estimated costs under this plan are summarized in Table 1. A summary of the estimated reimbursement schedule and the amount of capture into the LBRF by year and in aggregate is presented in Table 3.

## **2.4 Method of Financing and Description of Advances Made by the Municipality**

The eligible activities contemplated under this plan will be financed by the Developer, as outlined in this plan and the accompanying development and reimbursement agreement (Appendix 2). No advances from the city are anticipated at this time.

## **2.5 Maximum Amount of Note or Bonded Indebtedness**

At this time, there are no plans by the Authority to incur indebtedness to support the development of this site, but such plans could be made in the future to assist in the development if the Authority chooses.

## **2.6 Duration of Brownfield Plan**

The Authority intends to begin the capture of tax increment as early as 2027. This plan will then remain in place until the eligible activities have been fully reimbursed and up to five full years of capture into the LBRF (not to exceed the cost of eligible activities) or 30 years, whichever occurs sooner. An analysis showing the reimbursement schedule is attached as Table 3.

## **2.7 Estimated Impact of Tax Increment Financing on Revenues of Taxing Jurisdictions**

An estimate of the impact of TIF on the revenues of all taxing jurisdictions is illustrated in detail in Table 2.

## **2.8 Legal Description, Property Map, Statement of Qualifying Characteristics, and Personal Property**

The property is located in South Haven Charter Township, Van Buren County, Michigan, and consists of one parcel that totals approximately 10.16 acres. The parcel ID number for the property is below.

The legal description for the parcel is as follows:

Parcel ID No.: 80-17-011-032-61

75-N 11-1-17 684-705 1079-546 1293-296 1474-206 1517-767 1534-302 1643-611 \*\*\* COM AT N1/4 POST OF SEC, TH S0D21'10"E ON N&S 1/4 L 1196.17' TO BEG, TH CON S0D21'10"E ON SD 1/4 L 791.08', TH N88D06'50"E 390.08' TO W L OF I-196 HWY, TH N0D01'22"E ON SD W L 791.34', TH S88D06' 00"W 395.27' TO BEG. ALSO, THAT PT OF THE FOLLOWING DES LY S OF A L 812.31' S OF AND PAR TO N SEC L OF SEC. N 18 A OF W1/2 OF NW1/4 OF NE1/4. EX HWY I-196 ROW. ALSO EX N 521.24' OF W 33' FOR ROW. \*\*\* COMBINED ON 01/12/2026 FROM 80-17-011-032-60, 80-17-011-001-01; FOR 2026

The property is qualified as a "Housing Property." A map showing eligible property dimensions is attached as Figure 2.

## **2.9 Estimates of Residents and Displacement of Individuals/Families**

There are no residents or families residing at this property, and thus no residents, families, or individuals will be displaced by the project.

## **2.10 Plan for Relocation of Displaced Persons**

No persons reside on the eligible property. Therefore, this section is not applicable.

## **2.11 Provisions for Relocation Costs**

No persons reside on the eligible property. Therefore, this section is not applicable.

**2.12 Strategy for Compliance with Michigan’s Relocation Assistance Law**

No persons reside on the eligible property. Therefore, this section is not applicable.

**2.13 Other Material that the Authority or Governing Body Considers Pertinent**

No other material required.



# Figures





PLOT INFO: Z:\2025\2501886\CAD\GIS\Proj\Brownfield.aprx Layout: FIG02\_Site Map Date: 2/9/2026 1:24 PM User: ebuyc



**LEGEND**

 Approximate Property Boundary



**SITE MAP**

0 100 200 FEET



Hard copy is intended to be 8.5"x11" when plotted. Scale(s) indicated and graphic quality may not be accurate for any other size.

**SOHA Drift Lofts**  
73rd Street, South Haven, Michigan  
**Brownfield Plan**

PROJECT NO.  
2501886

FIGURE NO.  
**2**

DATA SOURCES: OSM HYBRID REFERENCE LAYER & MISAIL IMAGERY.

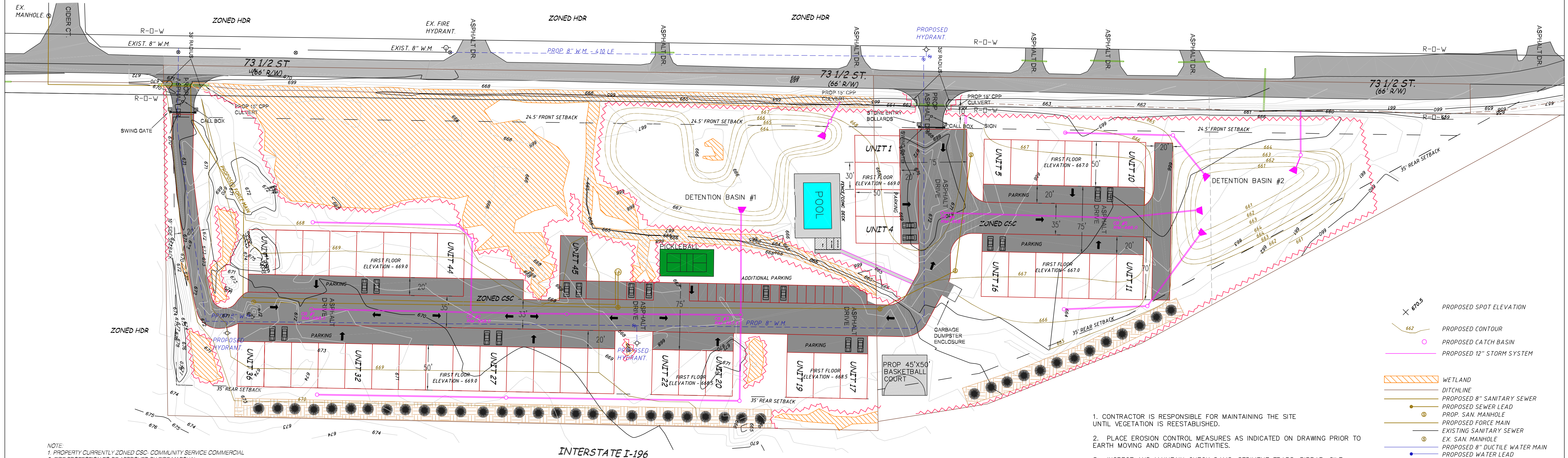
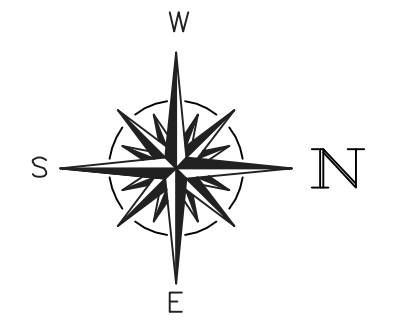
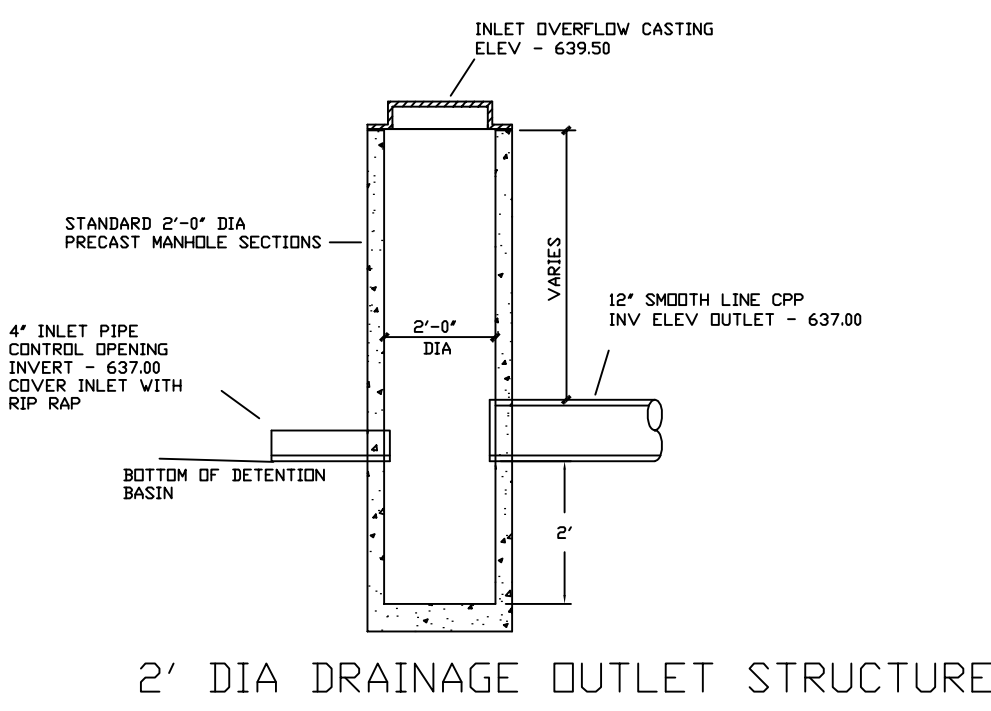
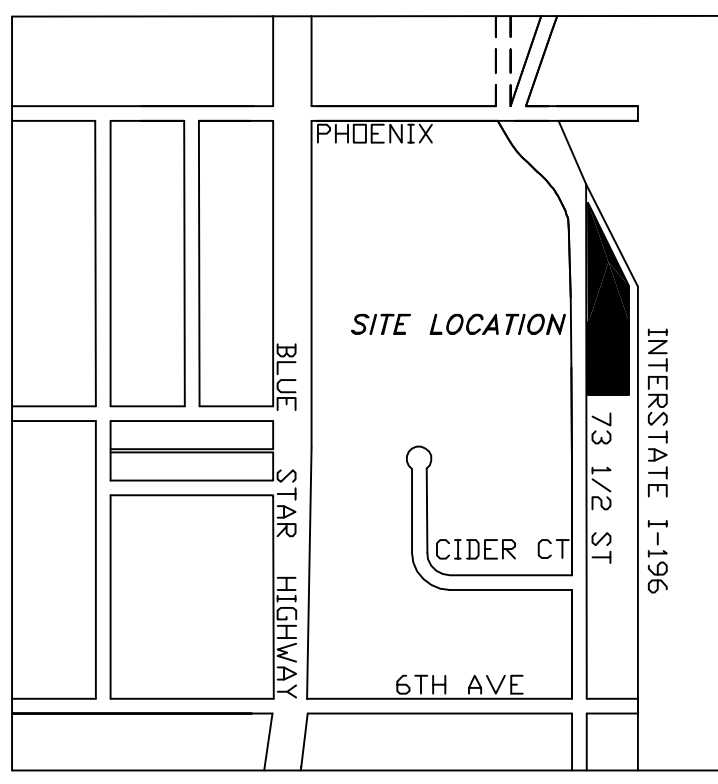

- NOTE:
1. PROPERTY CURRENTLY ZONED CSC - COMMUNITY SERVICE COMMERCIAL
  2. FIRE PROTECTION TO BE APPROVED BY FIRE MARSHAL
  3. UTILITIES
    - A. SEWER AND WATER - SOUTH HAVEN TOWNSHIP MUNICIPAL SYSTEMS
    - B. ELECTRIC - CITY OF SOUTH HAVEN
    - C. STORM WATER SYSTEM - ON-SITE WITH 25 YEAR DETENTION PER WCCDC STANDARDS W/O 13 CFS RELEASE PER ACRE.
  4. ALL PARKING WILL BE IN FRONT OF EACH BARNDOMINIUM AND INSIDE THE BARNDOMINIUMS. TWO SPACES PER BARNDOMINIUM. TWO IN FRONT (ALSO SPACES INSIDE). ADDITIONAL PARKING PROVIDED.
  5. PROPOSED SLIDE GATE SHALL HAVE KNOX BOX INSTALLED PER SHAES GUIDELINES
  6. BARNDOMINIUM LIGHTING SHALL BE WALL MOUNTED. EXTERIOR LIGHTS TO BE SHIELDED TO DIRECT LIGHT DOWNWARD AND COMPLY WITH SECTION 18.24 OF THE SOUTH HAVEN TOWNSHIP ZONING ORDINANCE.
  7. DEVELOPMENT SIGN SHALL NOT EXCEED 8 FEET IN HEIGHT OR 25 SQ FT IN AREA.
  8. ALL GUTTER DOWN SPOUTS WILL BE CONNECTED TO PROPOSED STORM SYSTEM.
  9. WATER SYSTEM TO BE CONSTRUCTED TO THE CITY OF SOUTH HAVEN SPECIFICATIONS.

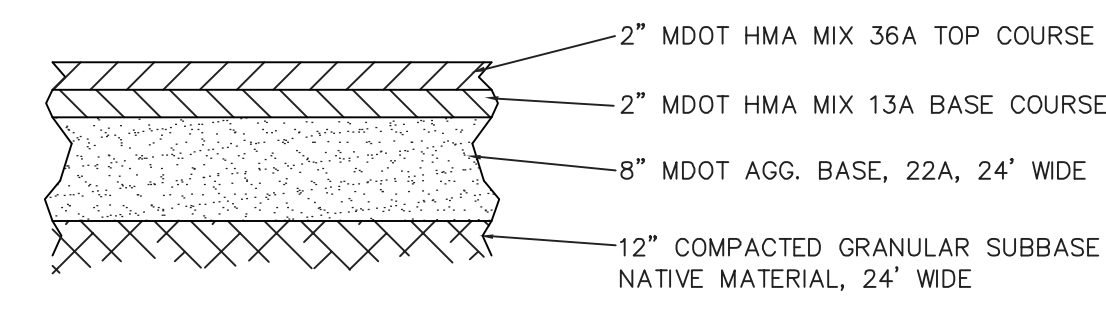
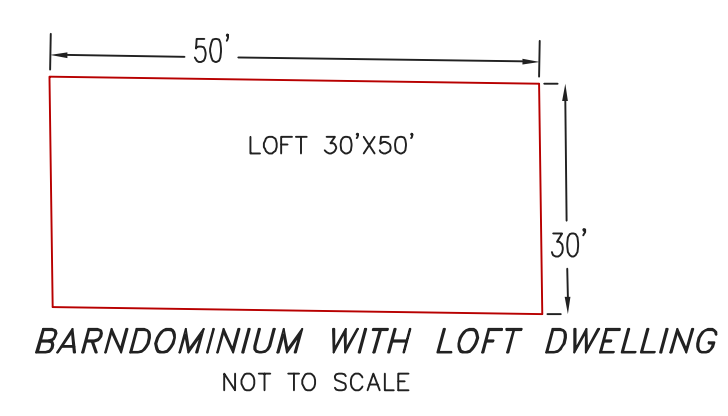

ROAD CROSS SECTION  
NOT TO SCALE

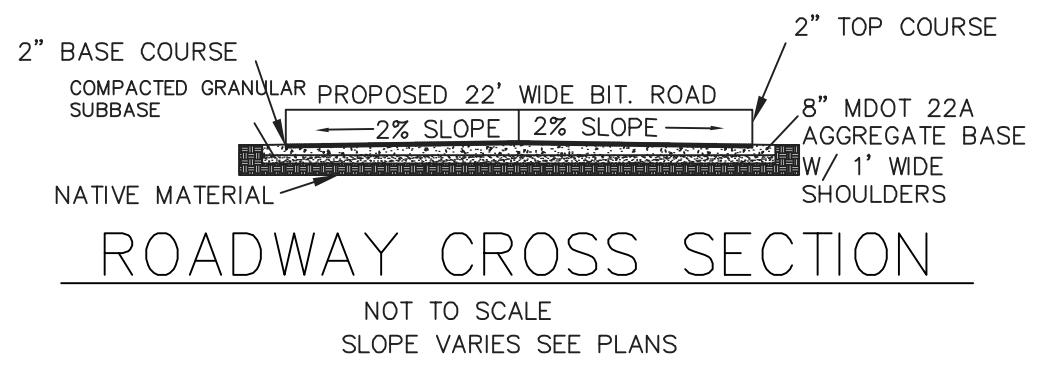

ROADWAY CROSS SECTION  
NOT TO SCALE  
SLOPE VARIES SEE PLANS

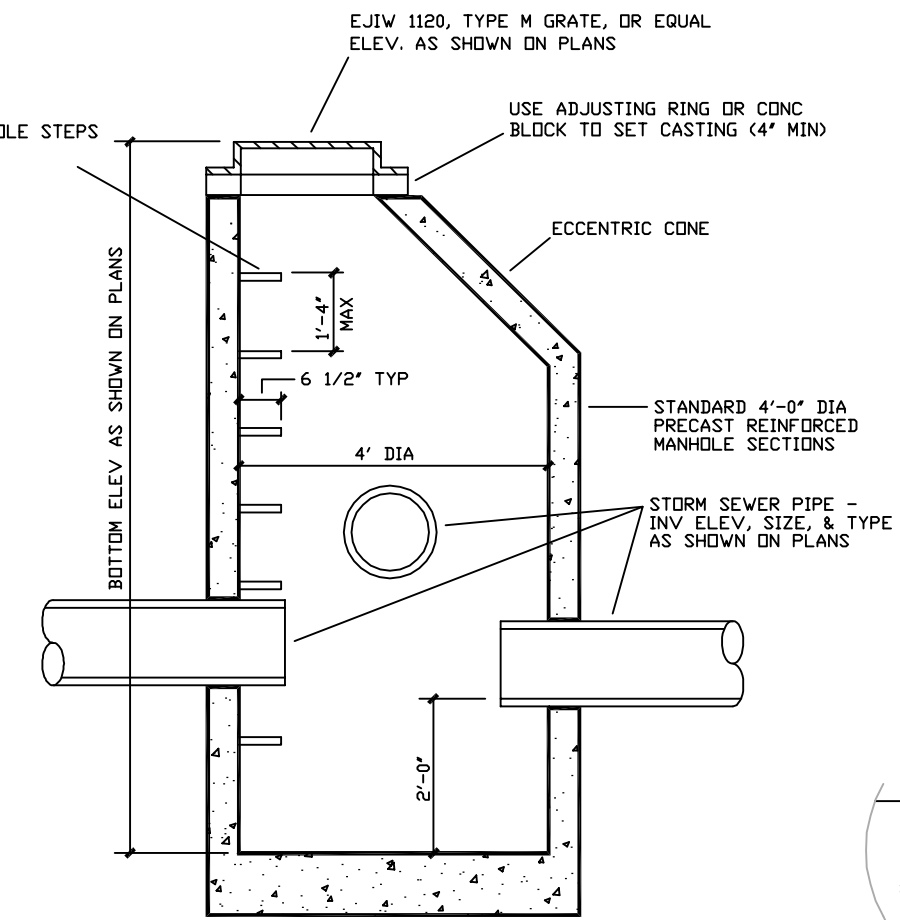

4' DIA DRAINAGE STRUCTURE

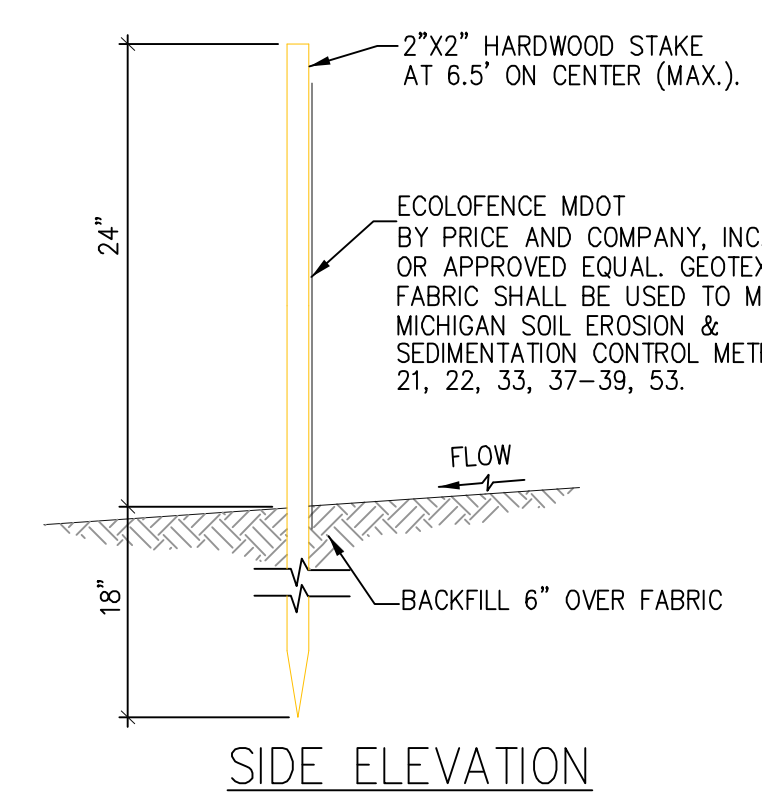

SIDE ELEVATION

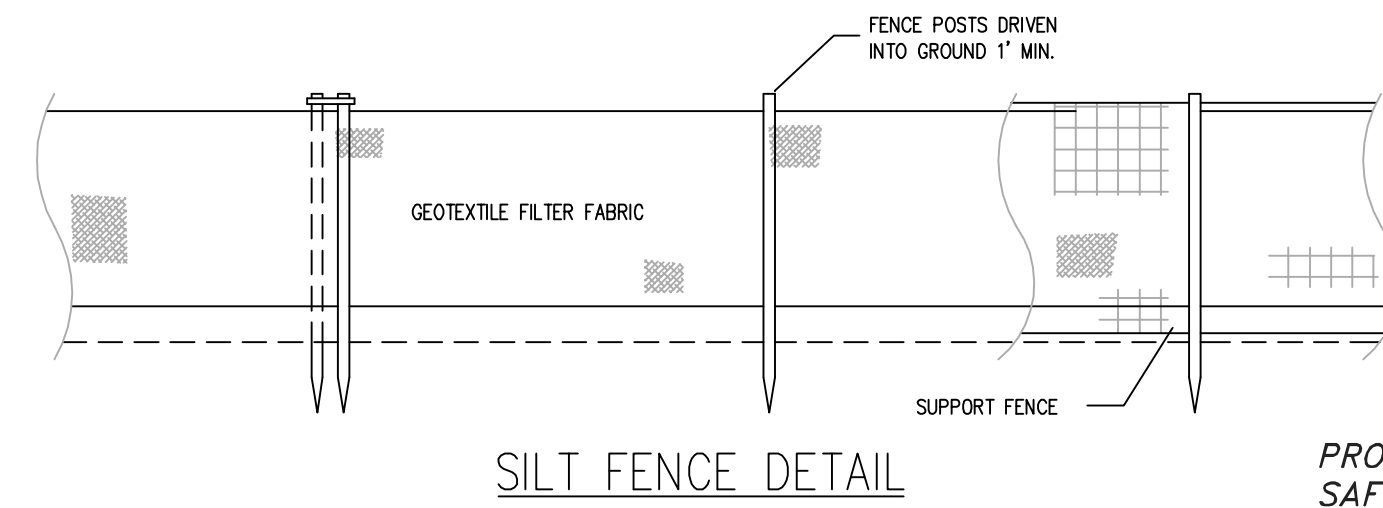

SILT FENCE DETAIL

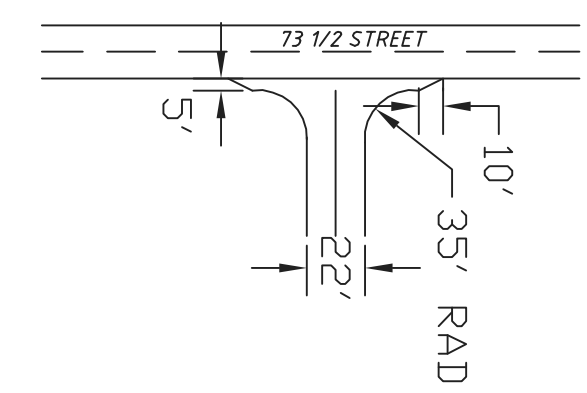

PROPOSED DRIVEWAY ENTRANCE DETAIL

1. DRIVEWAY ENTRANCE SHALL BE TO VAN BUREN COUNTY ROAD COMMISSION STANDARDS
2. DRIVEWAY APPROACH SHALL BE 12" MDOT CLASS II SAND, 8" MDOT 22A GRAVEL BASE, TOPPED WITH 2" HMA BASE AND 2" HMA TOP COURSE. SEE DETAIL.
3. PROPOSED CULVERTS SHALL BE 15" CMP
4. THERE IS NO EXISTING GRAVEL SHOULDER AT PROPOSED DRIVE LOCATION
5. NO OTHER UTILITIES OR TREES IN WAY OF PROPOSED DRIVEWAY.

1. CONTRACTOR IS RESPONSIBLE FOR MAINTAINING THE SITE UNTIL VEGETATION IS REESTABLISHED.
2. PLACE EROSION CONTROL MEASURES AS INDICATED ON DRAWING PRIOR TO EARTH MOVING AND GRADING ACTIVITIES.
3. INSPECT AND MAINTAIN CHECK DAMS, SEDIMENT TRAPS, RIPRAP, SILT FENCING, AND OTHER MEASURES AFTER STORM EVENTS AND AS NECESSARY TO ASSURE PROPER FUNCTION.
4. HYDRO SEED ALL DISTURBED AREAS AFTER PLACING 4" OF CLEAN TOPSOIL
5. EROSION CONTROL MEASURES SHALL REMAIN IN PLACE UNTIL VEGETATION IS UNIFORMLY ESTABLISHED. REGRADE, RESEED, AND PLACE ADDITIONAL TOPSOIL IN ERODED AREAS AS NECESSARY UNTIL FINAL LANDSCAPING IS INSTALLED.
6. ALL SWALES, SLOPES 1 ON 4 OR STEEPER, AND THE STORM WATER DETENTION AREA SHALL BE SEED AND MULCHED WITH NORTH AMERICAN GREEN S150 EROSION CONTROL BLANKET AS INDICATED ON DRAWINGS.
7. CONSTRUCTION OF SEDIMENT BASINS AND DIVERSION DITCHES SHALL BE COMPLETED PRIOR TO SITE CLEARING AND GRADING (IF APPLICABLE).
8. RIPRAP SHALL BE NATURAL STONE, SOLID PRECAST CONCRETE BLOCKS MADE FROM GRADE P2 CONCRETE, OR SOUND PIECES OF BROKEN CONCRETE, FREE FROM STRUCTURAL DEFECTS. PLAIN RIPRAP SHALL CONSIST OF INDIVIDUAL STONES OR PIECES OF BROKEN CONCRETE HAVING A LEAST DIMENSION OF 8 INCHES. SMALLER PIECES MAY BE USED TO FILL SPACES FOR BETTER PROTECTION OF THE SLOPE.
9. WRAP ALL GRATES IN GEOTEXTILE FABRIC. PLACE PEASTONE FILTER MATERIAL OVER STRUCTURES.
10. ALL SE/SC MEASURES TO BE BUILT PER MDEQ BMP MEASURES.
11. SE/SC MEASURES TO BE MAINTAINED & PROPERLY STAGED THROUGHOUT PROJECT.

- PROPOSED SPOT ELEVATION
- PROPOSED CONTOUR
- PROPOSED CATCH BASIN
- PROPOSED 12" STORM SYSTEM
- WETLAND
- DITCHLINE
- PROPOSED 8" SANITARY SEWER
- PROPOSED SAN MANHOLE
- PROPOSED FORCE MAIN
- EXISTING SANITARY SEWER
- EX SAN MANHOLE
- PROPOSED 8" DUCTILE WATER MAIN
- PROPOSED WATER LEAD
- EXISTING 8" WATER MAIN
- SETBACK
- UTILITY POLE
- PHONE PEDESTAL
- FOUND SURVEY MARKER
- FIRE HYDRANT
- WATER VALVE
- STREET SIGN
- WIRE FENCE
- EXISTING ASPHALT
- PROPOSED ASPHALT
- PROPOSED STORM WATER FLOW
- EXISTING GRADE
- SOIL BORING
- 5' TALL X 20' WIDE BERM
- CONIFEROUS TREE
- SILT FENCE

<b>MERRITT MIDWEST INC.</b> CIVIL ENGINEERING • LAND SURVEYING • ARCHITECTURE 13560 76TH STREET SOUTH HAVEN, MI 49089 PH: 269-637-9205 FX: 269-637-9206		<b>SOHA DRIFT LOFTS</b> SOUTH HAVEN, MI SESC PLAN SHEET 1 OF 1 PROJECT NO: 25-018	
PROPERTY OWNER: <b>SAFE AND EASY SELF STORAGE, LLC</b> 4890 PAW LAKE ROAD COLOMA, MI 49038 PHONE - 269.468.6001		SCALE: 1" = 50' DATE: 3/17/25 REVISED: RP	
FILE NAME:			



# Tables



**Table 1 – Summary of Eligible Costs**

Act 381 Brownfield Plan

SoHa Drift Lofts

73rd Street, South Haven

**MSHDA Eligible Activities Costs and Schedule**

MSHDA Eligible Activities	Cost	Completion Season/Year
<b>Infrastructure &amp; Safety Improvements Necessary to Support Housing</b>	<b>\$ 2,110,380</b>	
<i>Streets, roads</i>	\$ 378,222	
<i>Sidewalks</i>	\$ 55,730	
<i>Lighting</i>	\$ 75,000	
<i>Storm Sewers</i>	\$ 192,750	
<i>Electric &amp; Gas</i>	\$ 270,000	
<i>Water Mains &amp; Connections</i>	\$ 417,850	
<i>Curb &amp; Gutter</i>	\$ 140,000	
<i>Sanitary Sewer Mains &amp; Connections</i>	\$ 332,425	
<i>Landscaping</i>	\$ 99,250	
<i>Soft Costs (Engineering, Design, Survey, Legal, other Professional)</i>	\$ 149,153	
<b>MSHDA Eligible Activities Subtotal</b>	<b>\$ 2,110,380</b>	
<b>Contingency (15%)</b>	<b>\$ 316,557</b>	
<b>Brownfield Plan Preparation/Implementation</b>	<b>\$ 10,000</b>	
<b>MSHDA Eligible Activities Total Costs</b>	<b>\$ 2,436,937</b>	

Table 2 – Total Captured Incremental Taxes Schedule

Act 381 Brownfield Plan  
SoHa Drift Lofts  
73rd Street, South Haven

Estimated Taxable Value (TV) Increase Rate: 1% increase per year

Plan Year	1	2	3	4	5	6	7	8	9	10	11	12	13
Calendar Year	2027	2028	2029	2030	2031	2032	2033	2034	2035	2036	2037	2038	2039
*Base Taxable Value	\$ 25,953	\$ 25,953	\$ 25,953	\$ 25,953	\$ 25,953	\$ 25,953	\$ 25,953	\$ 25,953	\$ 25,953	\$ 25,953	\$ 25,953	\$ 25,953	\$ 25,953
Future Taxable Value	\$ 1,066,667	\$ 2,844,444	\$ 4,622,222	\$ 6,400,000	\$ 8,000,000	\$ 8,080,000	\$ 8,160,800	\$ 8,242,408	\$ 8,324,832	\$ 8,408,080	\$ 8,492,161	\$ 8,577,083	\$ 8,662,854
<b>Incremental Difference (New TV - Base TV)</b>	<b>\$ 1,040,714</b>	<b>\$ 2,818,491</b>	<b>\$ 4,596,269</b>	<b>\$ 6,374,047</b>	<b>\$ 7,974,047</b>	<b>\$ 8,054,047</b>	<b>\$ 8,134,847</b>	<b>\$ 8,216,455</b>	<b>\$ 8,298,879</b>	<b>\$ 8,382,127</b>	<b>\$ 8,466,208</b>	<b>\$ 8,551,130</b>	<b>\$ 8,636,901</b>

Local Capture	Millage Rate	1	2	3	4	5	6	7	8	9	10	11	12	13
South Haven Township Operating	0.5243	\$ 546	\$ 1,478	\$ 2,410	\$ 3,342	\$ 4,181	\$ 4,223	\$ 4,265	\$ 4,308	\$ 4,351	\$ 4,395	\$ 4,439	\$ 4,483	\$ 4,528
South Haven Police	0.7368	\$ 767	\$ 2,077	\$ 3,387	\$ 4,696	\$ 5,875	\$ 5,934	\$ 5,994	\$ 6,054	\$ 6,115	\$ 6,176	\$ 6,238	\$ 6,300	\$ 6,364
South Haven Roads	1.4246	\$ 1,483	\$ 4,015	\$ 6,548	\$ 9,080	\$ 11,360	\$ 11,474	\$ 11,589	\$ 11,705	\$ 11,823	\$ 11,941	\$ 12,061	\$ 12,182	\$ 12,304
South Haven Library	1.2274	\$ 1,277	\$ 3,459	\$ 5,641	\$ 7,824	\$ 9,787	\$ 9,886	\$ 9,985	\$ 10,085	\$ 10,186	\$ 10,288	\$ 10,391	\$ 10,496	\$ 10,601
South Haven Rec	0.2484	\$ 259	\$ 700	\$ 1,142	\$ 1,583	\$ 1,981	\$ 2,001	\$ 2,021	\$ 2,041	\$ 2,061	\$ 2,082	\$ 2,103	\$ 2,124	\$ 2,145
Senior Services	0.9825	\$ 1,023	\$ 2,769	\$ 4,516	\$ 6,263	\$ 7,835	\$ 7,913	\$ 7,992	\$ 8,073	\$ 8,154	\$ 8,235	\$ 8,318	\$ 8,401	\$ 8,486
VB CO Roads	0.9703	\$ 1,010	\$ 2,735	\$ 4,460	\$ 6,185	\$ 7,737	\$ 7,815	\$ 7,893	\$ 7,972	\$ 8,052	\$ 8,133	\$ 8,215	\$ 8,297	\$ 8,380
VB CO Ambulance	0.9353	\$ 973	\$ 2,636	\$ 4,299	\$ 5,962	\$ 7,458	\$ 7,533	\$ 7,609	\$ 7,685	\$ 7,762	\$ 7,840	\$ 7,918	\$ 7,998	\$ 8,078
VB CO Pub Safety	0.5322	\$ 554	\$ 1,500	\$ 2,446	\$ 3,392	\$ 4,244	\$ 4,286	\$ 4,329	\$ 4,373	\$ 4,417	\$ 4,461	\$ 4,506	\$ 4,551	\$ 4,597
VB CO Transit	0.2453	\$ 255	\$ 691	\$ 1,127	\$ 1,564	\$ 1,956	\$ 1,976	\$ 1,995	\$ 2,015	\$ 2,036	\$ 2,056	\$ 2,077	\$ 2,098	\$ 2,119
Conservation District	0.0989	\$ 103	\$ 279	\$ 455	\$ 630	\$ 789	\$ 797	\$ 805	\$ 813	\$ 821	\$ 829	\$ 837	\$ 846	\$ 854
Veterans Relief	0.0993	\$ 103	\$ 280	\$ 456	\$ 633	\$ 792	\$ 800	\$ 808	\$ 816	\$ 824	\$ 832	\$ 841	\$ 849	\$ 858
VB CO Parks	0.1000	\$ 104	\$ 282	\$ 460	\$ 637	\$ 797	\$ 805	\$ 813	\$ 822	\$ 830	\$ 838	\$ 847	\$ 855	\$ 864
VBISD Operating	0.1390	\$ 145	\$ 392	\$ 639	\$ 886	\$ 1,108	\$ 1,120	\$ 1,131	\$ 1,142	\$ 1,154	\$ 1,165	\$ 1,177	\$ 1,189	\$ 1,201
VBISD Spec Ed	4.1723	\$ 4,342	\$ 11,760	\$ 19,177	\$ 26,594	\$ 33,270	\$ 33,604	\$ 33,941	\$ 34,282	\$ 34,625	\$ 34,973	\$ 35,324	\$ 35,678	\$ 36,036
VBISD Voc Ed	2.4604	\$ 2,561	\$ 6,935	\$ 11,309	\$ 15,683	\$ 19,619	\$ 19,816	\$ 20,015	\$ 20,216	\$ 20,419	\$ 20,623	\$ 20,830	\$ 21,039	\$ 21,250
LMC	2.2654	\$ 2,358	\$ 6,385	\$ 10,412	\$ 14,440	\$ 18,064	\$ 18,246	\$ 18,429	\$ 18,614	\$ 18,800	\$ 18,989	\$ 19,179	\$ 19,372	\$ 19,566
VBC Allocated	4.4267	\$ 4,607	\$ 12,477	\$ 20,346	\$ 28,216	\$ 35,299	\$ 35,653	\$ 36,011	\$ 36,372	\$ 36,737	\$ 37,105	\$ 37,477	\$ 37,853	\$ 38,233
<b>Local Total</b>	<b>21.5891</b>	<b>\$ 22,468</b>	<b>\$ 60,849</b>	<b>\$ 99,229</b>	<b>\$ 137,610</b>	<b>\$ 172,152</b>	<b>\$ 173,880</b>	<b>\$ 175,624</b>	<b>\$ 177,386</b>	<b>\$ 179,165</b>	<b>\$ 180,963</b>	<b>\$ 182,778</b>	<b>\$ 184,611</b>	<b>\$ 186,463</b>

Non-Capturable Millages	Millage Rate	1	2	3	4	5	6	7	8	9	10	11	12	13
South Haven Debt	4.5000	\$ 4,683	\$ 12,683	\$ 20,683	\$ 28,683	\$ 35,883	\$ 36,243	\$ 36,607	\$ 36,974	\$ 37,345	\$ 37,720	\$ 38,098	\$ 38,480	\$ 38,866
South Haven Fire	3.6300	\$ 3,778	\$ 10,231	\$ 16,684	\$ 23,138	\$ 28,946	\$ 29,236	\$ 29,529	\$ 29,826	\$ 30,125	\$ 30,427	\$ 30,732	\$ 31,041	\$ 31,352
<b>Non-Capturable Total</b>	<b>8.1300</b>	<b>\$ 8,461</b>	<b>\$ 22,914</b>	<b>\$ 37,368</b>	<b>\$ 51,821</b>	<b>\$ 64,829</b>	<b>\$ 65,479</b>	<b>\$ 66,136</b>	<b>\$ 66,800</b>	<b>\$ 67,470</b>	<b>\$ 68,147</b>	<b>\$ 68,830</b>	<b>\$ 69,521</b>	<b>\$ 70,218</b>

**Total Tax Increment Revenue (TIR) Available for Capture** \$ 22,468 \$ 60,849 \$ 99,229 \$ 137,610 \$ 172,152 \$ 173,880 \$ 175,624 \$ 177,386 \$ 179,165 \$ 180,963 \$ 182,778 \$ 184,611 \$ 186,463

NOTES:

Table 2 – Total Captured Incremental Taxes Schedule

Act 381 Brownfield Plan  
SoHa Drift Lofts  
73rd Street, South Haven

Estimated Taxable Value (TV) Increase Rate:

Plan Year	14	15	16	17	18	19	20	21	22	Totals
Calendar Year	2040	2041	2042	2043	2044	2045	2046	2047	2048	
*Base Taxable Value	\$ 25,953	\$ 25,953	\$ 25,953	\$ 25,953	\$ 25,953	\$ 25,953	\$ 25,953	\$ 25,953	\$ 25,953	\$ -
Future Taxable Value	\$ 8,749,482	\$ 8,836,977	\$ 8,925,347	\$ 9,014,600	\$ 9,104,746	\$ 9,195,794	\$ 9,287,752	\$ 9,380,629	\$ 9,474,435	\$ -
<b>Incremental Difference (New TV - Base TV)</b>	<b>\$ 8,723,529</b>	<b>\$ 8,811,024</b>	<b>\$ 8,899,394</b>	<b>\$ 8,988,647</b>	<b>\$ 9,078,793</b>	<b>\$ 9,169,841</b>	<b>\$ 9,261,799</b>	<b>\$ 9,354,676</b>	<b>\$ 9,448,482</b>	

Local Capture	Millage Rate	14	15	16	17	18	19	20	21	22	Totals
South Haven Township Operating	0.5243	\$ 4,574	\$ 4,620	\$ 4,666	\$ 4,713	\$ 4,760	\$ 4,808	\$ 4,856	\$ 4,905	\$ 4,954	\$ 89,802
South Haven Police	0.7368	\$ 6,427	\$ 6,492	\$ 6,557	\$ 6,623	\$ 6,689	\$ 6,756	\$ 6,824	\$ 6,893	\$ 6,962	\$ 126,199
South Haven Roads	1.4246	\$ 12,428	\$ 12,552	\$ 12,678	\$ 12,805	\$ 12,934	\$ 13,063	\$ 13,194	\$ 13,327	\$ 13,460	\$ 244,006
South Haven Library	1.2274	\$ 10,707	\$ 10,815	\$ 10,923	\$ 11,033	\$ 11,143	\$ 11,255	\$ 11,368	\$ 11,482	\$ 11,597	\$ 210,229
South Haven Rec	0.2484	\$ 2,167	\$ 2,189	\$ 2,211	\$ 2,233	\$ 2,255	\$ 2,278	\$ 2,301	\$ 2,324	\$ 2,347	\$ 42,546
Senior Services	0.9825	\$ 8,571	\$ 8,657	\$ 8,744	\$ 8,831	\$ 8,920	\$ 9,009	\$ 9,100	\$ 9,191	\$ 9,283	\$ 168,283
VB CO Roads	0.9703	\$ 8,464	\$ 8,549	\$ 8,635	\$ 8,722	\$ 8,809	\$ 8,897	\$ 8,987	\$ 9,077	\$ 9,168	\$ 166,193
VB CO Ambulance	0.9353	\$ 8,159	\$ 8,241	\$ 8,324	\$ 8,407	\$ 8,491	\$ 8,577	\$ 8,663	\$ 8,749	\$ 8,837	\$ 160,199
VB CO Pub Safety	0.5322	\$ 4,643	\$ 4,689	\$ 4,736	\$ 4,784	\$ 4,832	\$ 4,880	\$ 4,929	\$ 4,979	\$ 5,028	\$ 91,155
VB CO Transit	0.2453	\$ 2,140	\$ 2,161	\$ 2,183	\$ 2,205	\$ 2,227	\$ 2,249	\$ 2,272	\$ 2,295	\$ 2,318	\$ 42,015
Conservation District	0.0989	\$ 863	\$ 871	\$ 880	\$ 889	\$ 898	\$ 907	\$ 916	\$ 925	\$ 934	\$ 16,940
Veterans Relief	0.0993	\$ 866	\$ 875	\$ 884	\$ 893	\$ 902	\$ 911	\$ 920	\$ 929	\$ 938	\$ 17,008
VB CO Parks	0.1000	\$ 872	\$ 881	\$ 890	\$ 899	\$ 908	\$ 917	\$ 926	\$ 935	\$ 945	\$ 17,128
VBISD Operating	0.1390	\$ 1,213	\$ 1,225	\$ 1,237	\$ 1,249	\$ 1,262	\$ 1,275	\$ 1,287	\$ 1,300	\$ 1,313	\$ 23,808
VBISD Spec Ed	4.1723	\$ 36,397	\$ 36,762	\$ 37,131	\$ 37,503	\$ 37,879	\$ 38,259	\$ 38,643	\$ 39,031	\$ 39,422	\$ 714,633
VBISD Voc Ed	2.4604	\$ 21,463	\$ 21,679	\$ 21,896	\$ 22,116	\$ 22,337	\$ 22,561	\$ 22,788	\$ 23,016	\$ 23,247	\$ 421,418
LMC	2.2654	\$ 19,762	\$ 19,960	\$ 20,161	\$ 20,363	\$ 20,567	\$ 20,773	\$ 20,982	\$ 21,192	\$ 21,405	\$ 388,019
VBC Allocated	4.4267	\$ 38,616	\$ 39,004	\$ 39,395	\$ 39,790	\$ 40,189	\$ 40,592	\$ 40,999	\$ 41,410	\$ 41,826	\$ 758,207
<b>Local Total</b>	<b>21.5891</b>	<b>\$ 188,333</b>	<b>\$ 190,222</b>	<b>\$ 192,130</b>	<b>\$ 194,057</b>	<b>\$ 196,003</b>	<b>\$ 197,969</b>	<b>\$ 199,954</b>	<b>\$ 201,959</b>	<b>\$ 203,984</b>	<b>\$ 3,697,789</b>

Non-Capturable Millages	Millage Rate	14	15	16	17	18	19	20	21	22	Totals
South Haven Debt	4.5000	\$ 39,256	\$ 39,650	\$ 40,047	\$ 40,449	\$ 40,855	\$ 41,264	\$ 41,678	\$ 42,096	\$ 42,518	\$ 770,762
South Haven Fire	3.6300	\$ 31,666	\$ 31,984	\$ 32,305	\$ 32,629	\$ 32,956	\$ 33,287	\$ 33,620	\$ 33,957	\$ 34,298	\$ 621,748
<b>Non-Capturable Total</b>	<b>8.1300</b>	<b>\$ 70,922</b>	<b>\$ 71,634</b>	<b>\$ 72,352</b>	<b>\$ 73,078</b>	<b>\$ 73,811</b>	<b>\$ 74,551</b>	<b>\$ 75,298</b>	<b>\$ 76,054</b>	<b>\$ 76,816</b>	<b>\$ 1,548,460</b>

**Total Tax Increment Revenue (TIR) Available for Capture** \$ 188,333 \$ 190,222 \$ 192,130 \$ 194,057 \$ 196,003 \$ 197,969 \$ 199,954 \$ 201,959 \$ 203,984 \$ **3,697,789**

NOTES:

**Table 3 – Estimated Reimbursement Schedule**  
 Act 381 Brownfield Plan  
 SoHa Drift Lofts  
 73rd Street, South Haven, Michigan

Developer Maximum Reimbursement	Proportionality	Local-Only Taxes	Total
<b>State</b>	<b>0.0%</b>	\$ -	\$ -
<b>Local</b>	<b>100.0%</b>	\$ 2,436,937	\$ 2,436,937
<b>TOTAL</b>			
Local Only	100.0%	\$ 2,436,937	\$ 2,436,937

Estimated Total  
 Years of Plan: **22**

Estimated Capture \$ 2,436,937  
 Administrative Fees \$ 184,887  
 Local Brownfield Revolving Fund \$ 957,849

	1	2	3	4	5	6	7	8	9	10	11	12	13
	2027	2028	2029	2030	2031	2032	2033	2034	2035	2036	2037	2038	2039
Total Local Incremental Revenue	\$ 22,468	\$ 60,849	\$ 99,229	\$ 137,610	\$ 172,152	\$ 173,880	\$ 175,624	\$ 177,386	\$ 179,165	\$ 180,963	\$ 182,778	\$ 184,611	\$ 186,463
BRA Administrative Fee	\$ 8,404	\$ 8,404	\$ 8,404	\$ 8,404	\$ 8,404	\$ 8,404	\$ 8,404	\$ 8,404	\$ 8,404	\$ 8,404	\$ 8,404	\$ 8,404	\$ 8,404
Local TIR Available for Reimbursement	\$ 14,064	\$ 52,445	\$ 90,825	\$ 129,206	\$ 163,749	\$ 165,476	\$ 167,220	\$ 168,982	\$ 170,761	\$ 172,559	\$ 174,374	\$ 176,207	\$ 178,059
<b>Total State &amp; Local TIR Available</b>	<b>\$ 14,064</b>	<b>\$ 52,445</b>	<b>\$ 90,825</b>	<b>\$ 129,206</b>	<b>\$ 163,749</b>	<b>\$ 165,476</b>	<b>\$ 167,220</b>	<b>\$ 168,982</b>	<b>\$ 170,761</b>	<b>\$ 172,559</b>	<b>\$ 174,374</b>	<b>\$ 176,207</b>	<b>\$ 178,059</b>

DEVELOPER	Beginning Balance	1	2	3	4	5	6	7	8	9	10	11	12	13
Reimbursement Balance	\$ 2,436,937	\$ 2,422,873	\$ 2,370,428	\$ 2,279,603	\$ 2,150,397	\$ 1,986,649	\$ 1,821,173	\$ 1,653,953	\$ 1,484,971	\$ 1,314,209	\$ 1,141,651	\$ 967,277	\$ 791,070	\$ 613,011

Local-Only Costs	\$ 2,436,937	\$ 2,436,937	\$ 2,422,873	\$ 2,370,428	\$ 2,279,603	\$ 2,150,397	\$ 1,986,649	\$ 1,821,173	\$ 1,653,953	\$ 1,484,971	\$ 1,314,209	\$ 1,141,651	\$ 967,277	\$ 791,070
Local Tax Reimbursement	\$ 2,436,937	\$ 14,064	\$ 52,445	\$ 90,825	\$ 129,206	\$ 163,749	\$ 165,476	\$ 167,220	\$ 168,982	\$ 170,761	\$ 172,559	\$ 174,374	\$ 176,207	\$ 178,059
<b>Total Local-Only Reimbursement Balance</b>	<b>\$ 2,422,873</b>	<b>\$ 2,370,428</b>	<b>\$ 2,279,603</b>	<b>\$ 2,150,397</b>	<b>\$ 1,986,649</b>	<b>\$ 1,821,173</b>	<b>\$ 1,653,953</b>	<b>\$ 1,484,971</b>	<b>\$ 1,314,209</b>	<b>\$ 1,141,651</b>	<b>\$ 967,277</b>	<b>\$ 791,070</b>	<b>\$ 613,011</b>	
<b>Total Annual Developer Reimbursement</b>	<b>\$ 14,064</b>	<b>\$ 52,445</b>	<b>\$ 90,825</b>	<b>\$ 129,206</b>	<b>\$ 163,749</b>	<b>\$ 165,476</b>	<b>\$ 167,220</b>	<b>\$ 168,982</b>	<b>\$ 170,761</b>	<b>\$ 172,559</b>	<b>\$ 174,374</b>	<b>\$ 176,207</b>	<b>\$ 178,059</b>	

**LOCAL BROWNFIELD REVOLVING FUND**

LBRF Deposits*	\$ -	\$ -	\$ -	\$ -	\$ -	\$ -	\$ -	\$ -	\$ -	\$ -	\$ -	\$ -	\$ -	\$ -
State Tax Capture	\$ -	\$ -	\$ -	\$ -	\$ -	\$ -	\$ -	\$ -	\$ -	\$ -	\$ -	\$ -	\$ -	\$ -
Local Tax Capture	\$ -	\$ -	\$ -	\$ -	\$ -	\$ -	\$ -	\$ -	\$ -	\$ -	\$ -	\$ -	\$ -	\$ -
<b>Total LBRF Capture</b>	<b>\$ -</b>	<b>\$ -</b>	<b>\$ -</b>	<b>\$ -</b>	<b>\$ -</b>	<b>\$ -</b>	<b>\$ -</b>	<b>\$ -</b>	<b>\$ -</b>	<b>\$ -</b>	<b>\$ -</b>	<b>\$ -</b>	<b>\$ -</b>	<b>\$ -</b>

\* Up to five years of capture for LBRF Deposits after eligible activities are reimbursed. May be taken from state and local TIR.

Footnotes:

**Table 3 – Estimated Reimbursement Schedule**

Act 381 Brownfield Plan  
 SoHa Drift Lofts  
 73rd Street, South Haven, Michigan

Developer Maximum Reimbursement	Proportionality
<b>State</b>	<b>0.0%</b>
<b>Local</b>	<b>100.0%</b>
<b>TOTAL</b>	
Local Only	100.0%

	14 2039	15 2040	16 2041	17 2042	18 2043	19 2044	20 2045	21 2046	22 2047	TOTAL
Total Local Incremental Revenue	\$ 188,333	\$ 190,222	\$ 192,130	\$ 194,057	\$ 196,003	\$ 197,969	\$ 199,954	\$ 201,959	\$ 203,984	\$ 3,697,789
BRA Administrative Fee	\$ 8,404	\$ 8,404	\$ 8,404	\$ 8,404	\$ 8,404	\$ 8,404	\$ 8,404	\$ 8,404	\$ 8,404	\$ 184,887
Local TIR Available for Reimbursement	\$ 179,929	\$ 181,818	\$ 183,726	\$ 185,653	\$ 187,599	\$ 189,565	\$ 191,550	\$ 193,555	\$ 195,580	\$ 3,512,902
<b>Total State &amp; Local TIR Available</b>	<b>\$ 179,929</b>	<b>\$ 181,818</b>	<b>\$ 183,726</b>	<b>\$ 185,653</b>	<b>\$ 187,599</b>	<b>\$ 189,565</b>	<b>\$ 191,550</b>	<b>\$ 193,555</b>	<b>\$ 195,580</b>	<b>\$ 3,512,902</b>
<b>DEVELOPER</b>										
	Beginning Balance									
Reimbursement Balance	\$ 2,436,937	\$ 433,082	\$ 251,263	\$ 67,538	\$ -	\$ -	\$ -	\$ -	\$ -	\$ -
<hr/>										
Local-Only Costs	\$ 2,436,937	\$ 613,011	\$ 433,082	\$ 251,263	\$ 67,538	\$ -	\$ -	\$ -	\$ -	\$ -
Local Tax Reimbursement	\$ 2,436,937	\$ 179,929	\$ 181,818	\$ 183,726	\$ 67,538	\$ -	\$ -	\$ -	\$ -	\$ 2,436,937
<b>Total Local-Only Reimbursement Balance</b>	<b>\$ 433,082</b>	<b>\$ 251,263</b>	<b>\$ 67,538</b>	<b>\$ -</b>	<b>\$ -</b>	<b>\$ -</b>	<b>\$ -</b>	<b>\$ -</b>	<b>\$ -</b>	<b>\$ 2,436,937</b>
<b>Total Annual Developer Reimbursement</b>	<b>\$ 179,929</b>	<b>\$ 181,818</b>	<b>\$ 183,726</b>	<b>\$ 67,538</b>	<b>\$ -</b>	<b>\$ -</b>	<b>\$ -</b>	<b>\$ -</b>	<b>\$ -</b>	<b>\$ 2,436,937</b>
<b>LOCAL BROWNFIELD REVOLVING FUND</b>										
LBRF Deposits *	\$ -	\$ -	\$ -	\$ -	\$ -	\$ -	\$ -	\$ -	\$ -	\$ -
State Tax Capture	\$ -	\$ -	\$ -	\$ -	\$ -	\$ -	\$ -	\$ -	\$ -	\$ -
Local Tax Capture	\$ -	\$ -	\$ -	\$ 118,115	\$ 187,599	\$ 189,565	\$ 191,550	\$ 193,555	\$ 77,465	\$ 957,849
<b>Total LBRF Capture</b>	<b>\$ -</b>	<b>\$ -</b>	<b>\$ -</b>	<b>\$ -</b>	<b>\$ -</b>	<b>\$ -</b>	<b>\$ -</b>	<b>\$ -</b>	<b>\$ -</b>	<b>\$ -</b>

\* Up to five years of capture for LBRF Deposits after eligible

Footnotes:

# Appendix

# 1

**SOUTH HAVEN CHARTER TOWNSHIP, MICHIGAN**

**RESOLUTION SUPPORTING THE ADOPTION OF A BROWNFIELD PLAN  
SOHA DRIFT LOFTS, SOUTH HAVEN CHARTER TOWNSHIP, VAN BUREN COUNTY, MICHIGAN  
BY SOUTH HAVEN CHARTER TOWNSHIP  
PURSUANT TO AND IN ACCORDANCE WITH  
THE PROVISIONS OF ACT 381 OF THE PUBLIC ACTS  
OF THE STATE OF MICHIGAN OF 1996, AS AMENDED**

At a regular meeting of the South Haven Charter Township Board of Trustees, South Haven, Michigan, held at the South Haven Charter Township Hall located at 09761 Blue Star Memorial Hwy, South Haven, MI 49090, on the \_\_\_\_\_ day of \_\_\_\_\_ 2026 at \_\_\_\_ PM.

PRESENT:

ABSENT:

MOTION BY:

SUPPORTED BY:

WHEREAS, South Haven Charter Township, pursuant to and in accordance with the provisions of the Brownfield Redevelopment Financing Act, being Act 381 of the Public Acts of the State of Michigan of 1996, as amended (the "Act"), has formally resolved to participate in the Van Buren County Brownfield Redevelopment Authority (the "Authority") and have designated that all related activities shall proceed through the Authority; and

WHEREAS, the Authority, pursuant to and in accordance with Section 13 of the Act, has reviewed and recommended for approval by the Brownfield Plan (the "Plan") attached hereto, to be carried out within South Haven Charter Township, relating to the development of property located at 73<sup>rd</sup> Street, Michigan (the "Site"), as shown in Figures 1 and 2 of the Plan and more particularly described in the legal description of the property contained within the attached Plan; and

WHEREAS, the South Haven Charter Township Board of Trustees have reviewed the Plan, and have been provided with a reasonable opportunity to express their views and recommendations regarding the Plan and in accordance with Section 14(5) of the Act; and

WHEREAS, the Van Buren County Brownfield Redevelopment Authority has passed a resolution supporting the adoption of the Plan;

WHEREAS, the South Haven Charter Township Board of Trustees have made the following determinations and findings:

1. The Plan constitutes a public purpose under the Act;
2. The Plan meets all of the requirements for a Brownfield plan set forth in Section 13 of the

- Act;
3. The proposed method of financing the costs of the eligible activities, as described in the Plan, was feasible and the Authority has the ability to arrange the financing;
  4. The costs of the eligible activities proposed in the Plan are reasonable and necessary to carry out the purposes of the Act; and
  5. The amount of captured taxable value estimated to result from the adoption of the Plan is reasonable; and

WHEREAS, as a result of the review of the Plan the South Haven Charter Township Board of Trustees concurs with the approval of the individual Plan.

NOW, THEREFORE BE IT RESOLVED THAT:

1. **Plan Support.** Pursuant to the authority vested in the South Haven Charter Township Board of Trustees, by the Act, the Plan is hereby supported in the form attached to this Resolution.
2. **Severability.** Should any section, clause, or phrase of this Resolution be declared by the courts to be invalid, the same shall not affect the validity of this Resolution as a whole nor any part thereof other than the part so declared to be invalid.
3. **Repeals.** All resolutions or parts of resolutions in conflict with any of the provisions of this Resolution are hereby repealed.

AYES:

NAYES:

ABSTAINED:

RESOLUTION DECLARED ADOPTED.

STATE OF MICHIGAN )

)§

VAN BUREN COUNTY )ss:

I, the undersigned, the fully qualified and South Haven Charter Township Clerk, State of Michigan, do hereby certify that the foregoing is a true and complete copy of a resolution adopted by the South Haven Charter Township Board of Trustees at a regular meeting held on the \_\_\_\_ day of \_\_\_\_\_ 2026, the original of which resolution is on file in my office.

IN WITNESS WHEREOF, I have hereunto set my official signature  
this \_\_\_\_ day of \_\_\_\_\_ 2026.

---

Brenda Bertorelli

South Haven Charter Township Clerk

**VAN BUREN COUNTY, MICHIGAN**

**RESOLUTION ADOPTING A BROWNFIELD PLAN  
SOHA DRIFT LOFTS, SOUTH HAVEN CHARTER TOWNSHIP, MICHIGAN  
BY THE COUNTY OF VAN BUREN  
PURSUANT TO AND IN ACCORDANCE WITH  
THE PROVISIONS OF ACT 381 OF THE PUBLIC ACTS  
OF THE STATE OF MICHIGAN OF 1996, AS AMENDED**

At a regular meeting of the Board of Commissioners of Van Buren County, Michigan, held in the Don Hanson Board of Commissioners Chambers, Van Buren County Administration Building located at 219 E. Paw Paw Street, Second Floor, Paw Paw, MI 49079 on the \_\_\_ day of \_\_ 2026 at \_\_ PM.

PRESENT:

ABSENT:

MOTION BY:

SUPPORTED BY:

WHEREAS, Van Buren County, pursuant to and in accordance with the provisions of the Brownfield Redevelopment Financing Act, being Act 381 of the Public Acts of the State of Michigan of 1996, as amended (the "Act"), has established the Brownfield Redevelopment Authority of Van Buren County (the "Authority") and have designated that all related activities shall proceed through the Authority; and

WHEREAS, the Authority, pursuant to and in accordance with Section 13 of the Act, has reviewed, and recommended for adoption by the Van Buren County Board of Commissioners, the Brownfield Plan (the "Plan") attached hereto, to be carried out within South Haven Charter Township, relating to the development of property located at 73<sup>rd</sup> Street, South Haven, Michigan, (the "Site"), as shown in Figures 1 and 2 of the Plan and more particularly described in the legal description of the property contained within the attached Plan; and

WHEREAS, the Van Buren County Board of Commissioners have reviewed the Plan, and have been provided with a reasonable opportunity to express their views and recommendations regarding the Plan and in accordance with Section 14(5) of the Act; and

WHEREAS, the Van Buren County Board of Commissioners have noticed and held a public hearing in accordance with Section 14 (1, 2, 3, 4, and 5) of the Act, and

WHEREAS, the Van Buren County Brownfield Redevelopment Authority and the South Haven Charter Township Board of Trustees have passed a resolution supporting the adoption of the Plan;

WHEREAS, the Van Buren County Board of Commissioners have made the following determinations and findings:

1. The Plan constitutes a public purpose under the Act;
2. The Plan meets all of the requirements for a Brownfield plan set forth in Section 13 of the Act;
3. The proposed method of financing the costs of the eligible activities, as described in the Plan, was feasible and the Authority has the ability to arrange the financing;
4. The costs of the eligible activities proposed in the Plan are reasonable and necessary to carry out the purposes of the Act; and
5. The amount of captured taxable value estimated to result from the adoption of the Plan is reasonable; and

WHEREAS, as a result of the review of the Plan the Van Buren County Board of Commissioners concur with the adoption of the individual Plan.

NOW, THEREFORE BE IT RESOLVED THAT:

1. **Plan Support.** Pursuant to the authority vested in the Van Buren County Board of Commissioners, by the Act, the Plan is hereby supported in the form attached to this Resolution.
2. **Severability.** Should any section, clause, or phrase of this Resolution be declared by the courts to be invalid, the same shall not affect the validity of this Resolution as a whole nor any part thereof other than the part so declared to be invalid.
3. **Repeals.** All resolutions or parts of resolutions in conflict with any of the provisions of this Resolution are hereby repealed.

AYES:

NAYES:

ABSTAINED:

RESOLUTION DECLARED ADOPTED.

STATE OF MICHIGAN )

)§

VAN BUREN COUNTY )

I, the undersigned, the fully qualified and acting Clerk of Van Buren County, State of Michigan, do hereby certify that the foregoing is a true and complete copy of a resolution adopted by the Van Buren County Board of Commissioners at a regular meeting held on the \_\_\_ day of \_\_\_ 2026, the original of which resolution is on file in my office.

IN WITNESS WHEREOF, I have hereunto set my official signature  
this \_\_\_ day of \_\_\_ 2026.

---

Suzie Roehm

Van Buren County Clerk

# Appendix

# 2

**Page Intentionally Left Blank**

Development and Reimbursement Agreement Pending

# Appendix

# 3

## NOTICE TO ALL TAXING JURISDICTIONS

The Van Buren County Board of Commissioner proposes to approve a Brownfield Plan for a property in South Haven Charter Township, Michigan.

Van Buren County has established a Brownfield Redevelopment Authority (the "Authority") in accordance with the Brownfield Redevelopment Act, Act No. 381 of the Michigan Public Acts of 1996, as amended (the "Act"). The Act was enacted to provide a means for local units of government to facilitate the revitalization of environmentally impacted, functionally obsolete, blighted, or housing development properties. The Act permits the use of the tax increment financing in order to provide the Authority with the means of financing the redevelopment project included in a Brownfield Plan.

The Authority Board has reviewed and recommended the adoption of a Brownfield Plan related to the development of one parcel of property located at 73rd Street, South Haven, Michigan. The property is one vacant parcel that will be developed into 45 owner-occupied housing units. The total project investment is anticipated to total \$16,000,000.

The property qualifies as "eligible property" under the Brownfield Redevelopment Financing Act, 1996 PA 381, as amended ("Act 381"), on the basis of meeting the definition of a "Housing Property" in Section 2(p)(ii).

This Brownfield Plan provides a means for the developer to recover its costs of eligible activities which primarily include infrastructure and safety improvements necessary to support housing.

The plan will be considered for adoption at the \_\_\_\_\_, 2026 meeting of the Van Buren County Board of Commissioners held at \_\_\_\_\_ P.M. at Don Hanson Board of Commissioners Chambers, 219 E. Paw Paw Street, Second Floor, Paw Paw, MI 49079. If you have any questions or comments concerning the Brownfield Redevelopment Authority or the adoption of the Plan you may attend the meeting and express those concerns during the Public Hearing. You may also direct inquiries to Lisa Ransler at 269-657-8200 ext.1073 or [ranslerl@vanburencountymi.gov](mailto:ranslerl@vanburencountymi.gov).

Dated: \_\_\_\_\_, 2026

# Appendix

# 4

**NOTICE OF PUBLIC HEARING**

**VAN BUREN COUNTY BOARD OF COMMISSIONERS**

**REGARDING THE ADOPTION OF A BROWNFIELD PLAN  
THE SOHA DRIFT LOFTS, SOUTH HAVEN CHARTER TOWNSHIP  
VAN BUREN COUNTY, MICHIGAN**

**TO ALL INTERESTED PERSONS IN VAN BUREN COUNTY**

PLEASE TAKE NOTICE that the Van Buren County Board of Commissioners will hold a Public Hearing on a Brownfield Plan for SOHA Drift Lofts the \_\_\_ day of \_\_\_ 2026, at approximately \_\_\_, Eastern Daylight time held at the Van Buren County Board of Commissioners Chambers – 219 E. Paw Paw Street, Paw Paw, MI to receive public comment on a Brownfield Redevelopment Plan to include therein the property located at 73<sup>rd</sup> Street, South Haven Charter Township, Van Buren County, Michigan. The following legal parcel is included in the “eligible property”:

- Parcel IDs # 80-17-011-032-61

The project consists of two parcels in South Haven Charter Township. The project will involve the redevelopment of a 10.16-acre site into 45 new owner-occupied housing units. Primary eligible activities include infrastructure and safety improvements to support housing activities.

The property qualifies as “eligible property” under the Brownfield Redevelopment Financing Act, 1996 PA 381, as amended (“Act 381”), on the basis of meeting the definition of a “Housing Property” in Section 2(p)(ii).

The Brownfield Plan, which includes a site map and legal description of the parcel, is available for public inspection at the Van Buren County Administration Building. All aspects of the plan are open for discussion at the public hearing.

FURTHER INFORMATION may be obtained from Lisa Ransler at 269-657-8200 ext.1073 or [ranslerl@vanburencountymi.gov](mailto:ranslerl@vanburencountymi.gov).

THIS NOTICE is given by order of the Van Buren County, Michigan.

Suzie Roehm  
Van Buren County Clerk

# Appendix

# 5

# South Haven

Population	Households	Median HH Income	Owner HH Income	Renter HH Income
10,621	4,803	\$44,724	\$61,939	\$24,932

## Housing Costs

### Owner Units

Home Value	\$217,749	2016 Value	\$163,655
Cost M/NM	\$1605/\$536	Value ▲	33.1%

\$72,583 To afford median home

### Renter Units

Gross Rent	\$786	2016 Rent	\$718
		Rent ▲	9.4%

\$31,440 To afford median gross rent

## Affordability Gap

### Monthly Costs: Owners and Renters

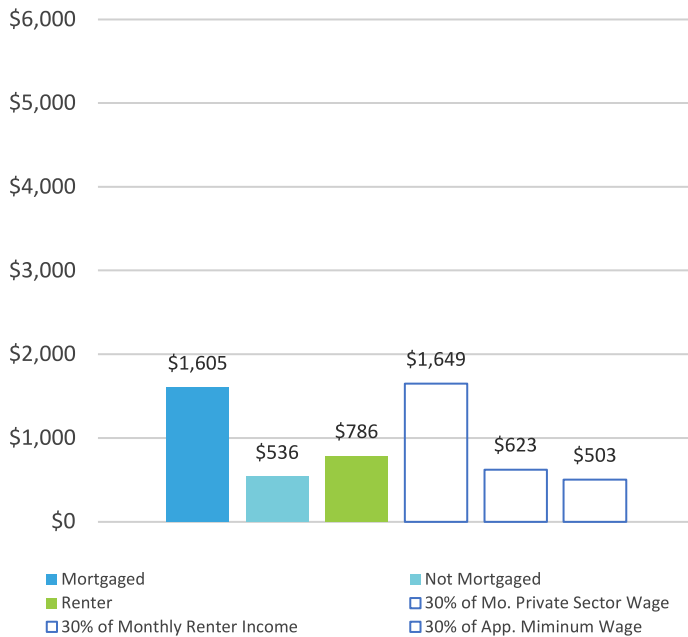

### Cost-Burdened Households

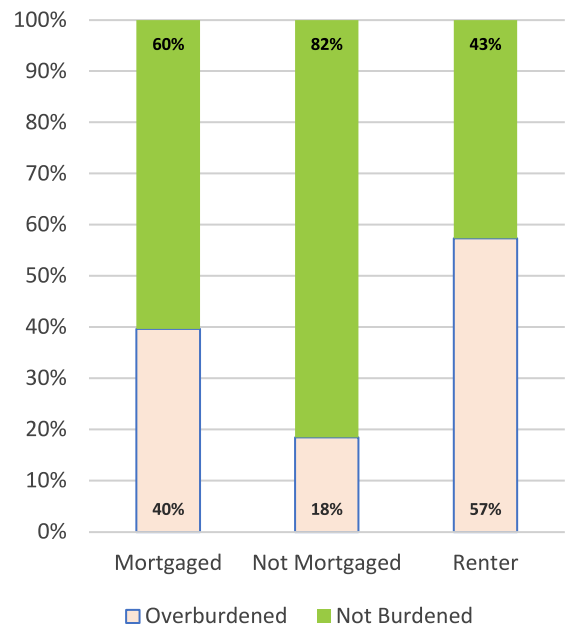

## Housing and Development Conditions

### Housing Stock

Units	7,206	Owner HH	66%	Renter HH	34%
Median Year Built	1967	% Built Pre-1970			51.8%
Median Move Year	2010	% Built After 2010			1.9%
Median Rooms	5.6	SF%	67.2%	MM%	12.9%
		MF%			9.7%

### Vacancy Rates

Total	33.3%	Owner	0%	Renter	0.1%
Seasonal	24.4%	Other	4.1%	# V Rent	130
				# V Owner	0

### Homeownership Rate by Race/Ethnicity

Black	31.8%	White	71.9%
Asian	47.7%	Other or Multiracial	67.7%
Am. Indian	0.0%	Hispanic	56.1%
Pacific Islnd	0.0%		

### Number of Households by AMI Group

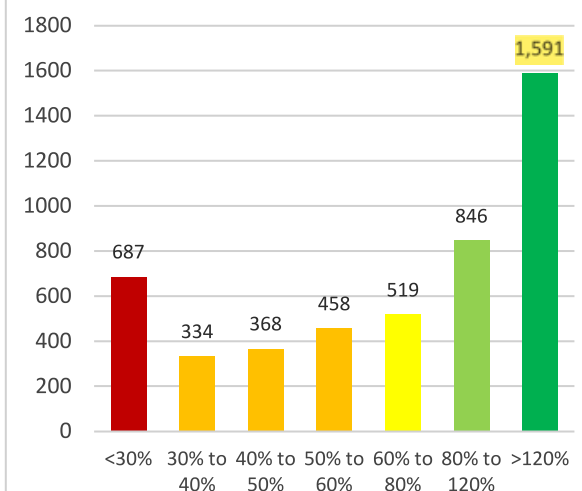

# Appendix

# 6

DRAWINGS FOR:  
**SOHA DRIFT LOFTS**

73rd Street South Haven MI



5844 RED ARROW HIGHWAY  
STEVENSVILLE, MICHIGAN 49127  
PHONE: (269) 429-7000  
FAX: (269) 429-7888  
EMAIL: ade@brooksarch.com

© BROOKS ARCHITECTURAL INC. 2025



DRAWN BY: cv
APPROVED BY: aa
REVISIONS
PROJECT: 25-030C
DATE: 8-4-2025
SHEET
<b>T-1</b>
OF XX

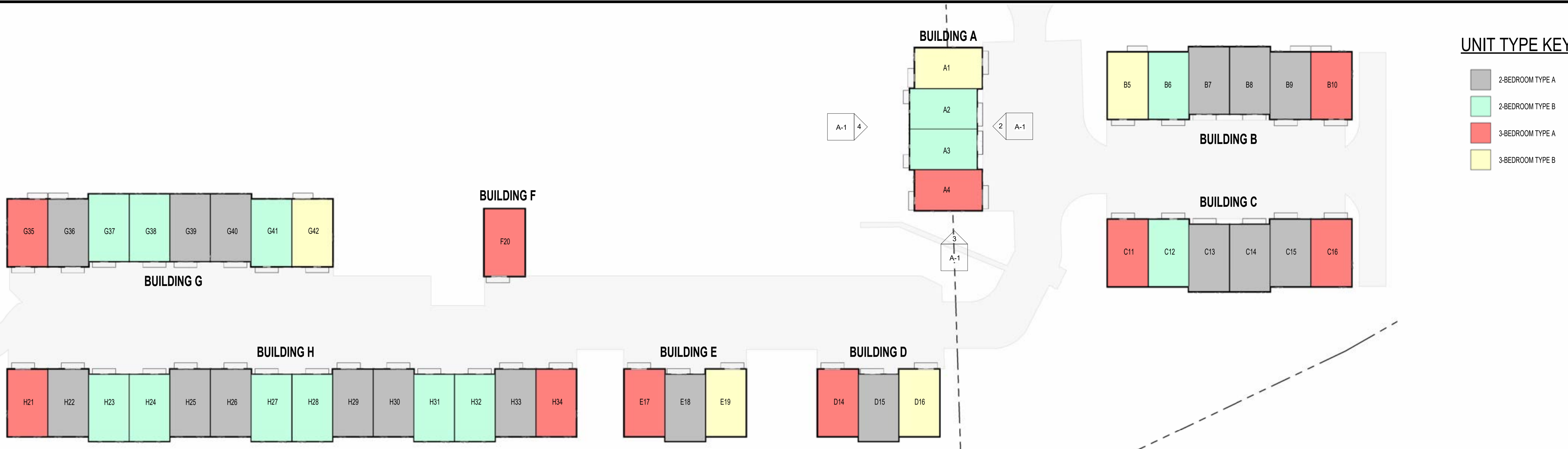

1  
A-1  
**LOFT UNIT TYPE - OVERALL**  
1" = 40'-0"

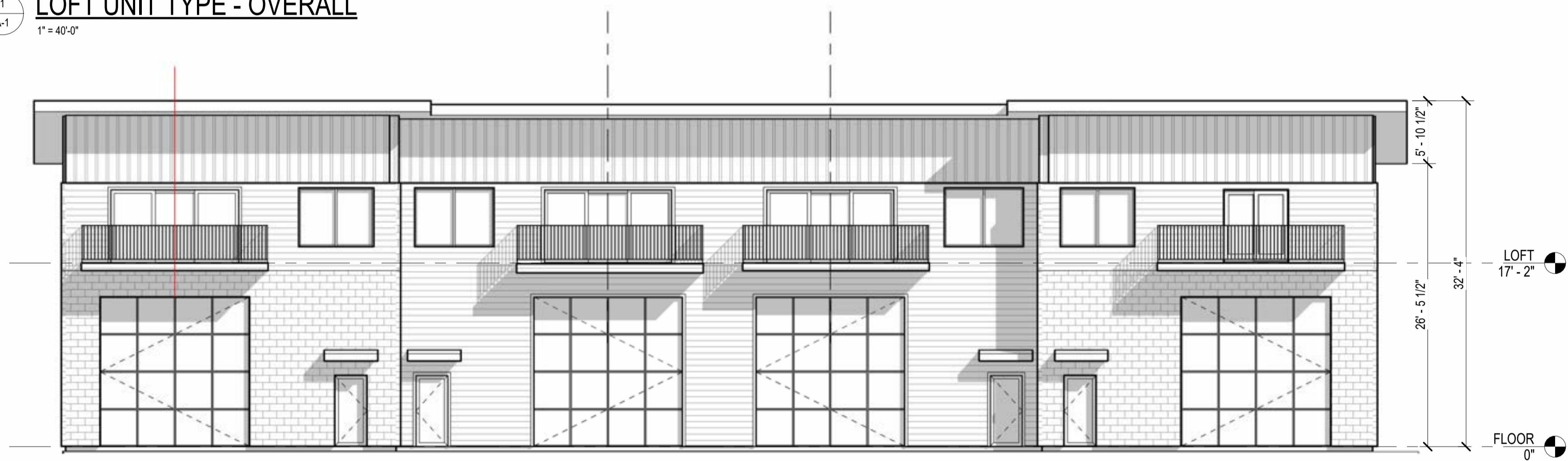

2  
A-1  
**BUILDING A - FRONT ELEVATION**  
1/8" = 1'-0"

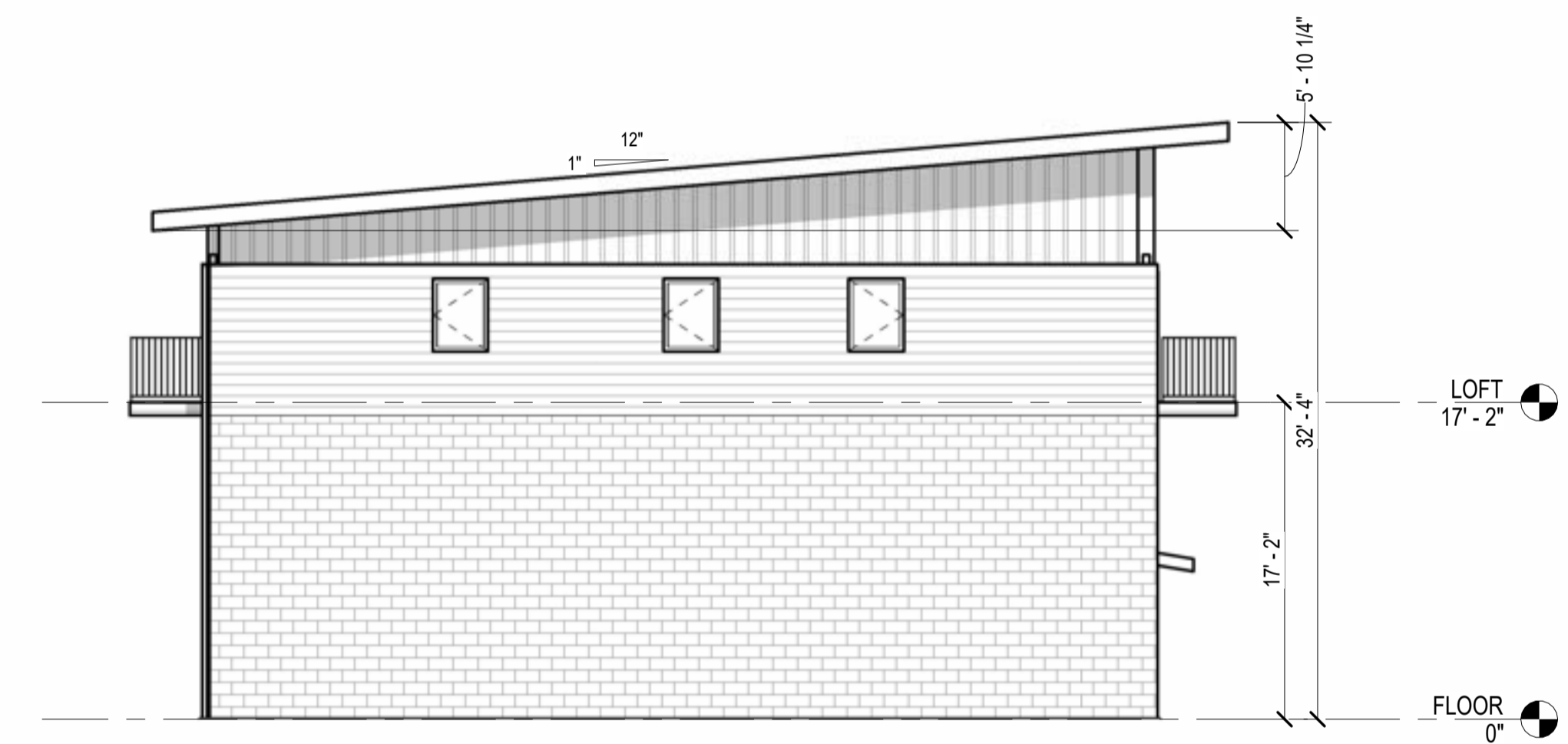

3  
A-1  
**BUILDING A - SIDE ELEVATION**  
1/8" = 1'-0"

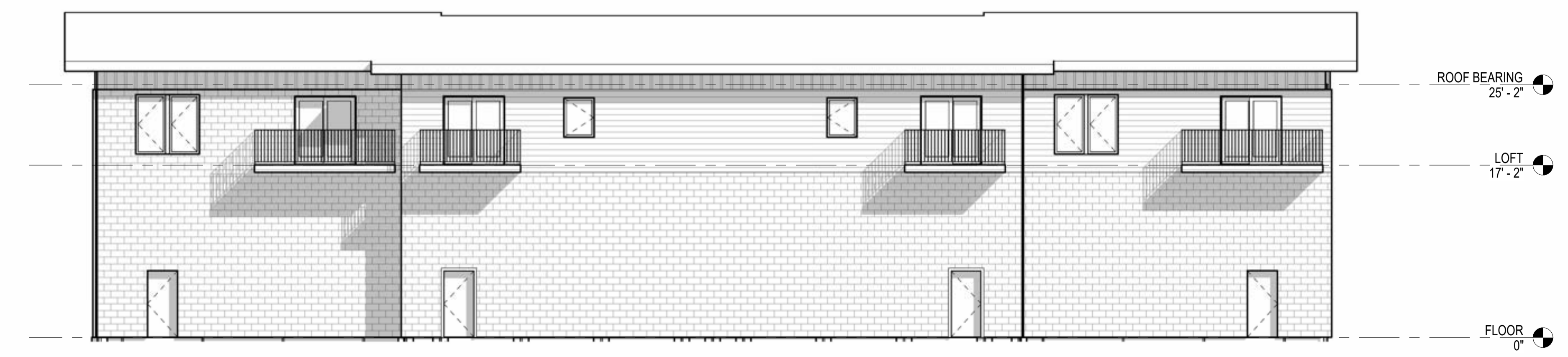

4  
A-1  
**BUILDING A - BACK ELEVATION**  
1/8" = 1'-0"

**PRELIMINARY ONLY**  
NOT FOR CONSTRUCTION

5844 RED ARROW HIGHWAY  
STEVENSVILLE, MICHIGAN 49127  
Phone: (269) 429-7000  
Fax: (269) 429-7888  
Email: ade@brooksrch.com  
© BROOKS ARCHITECTURAL, INC. 2023

**BROOKS**  
ARCHITECTURAL

**UNIT LAYOUT & ELEVATIONS**  
DRAWINGS FOR:  
**SOUTH HAVEN BARNDOMINIUMS**  
73rd Street South Haven MI

DRAWN BY: XX  
APPROVED BY: XX  
REVISIONS

PROJECT: 25-030C  
DATE: 8-4-2025

SHEET  
**A-1**  
OF XX

P:\Celeena\25-030C Barndominiums\Storage  
Lofts JULY.rvt  
8/4/2025 3:53:50 PM

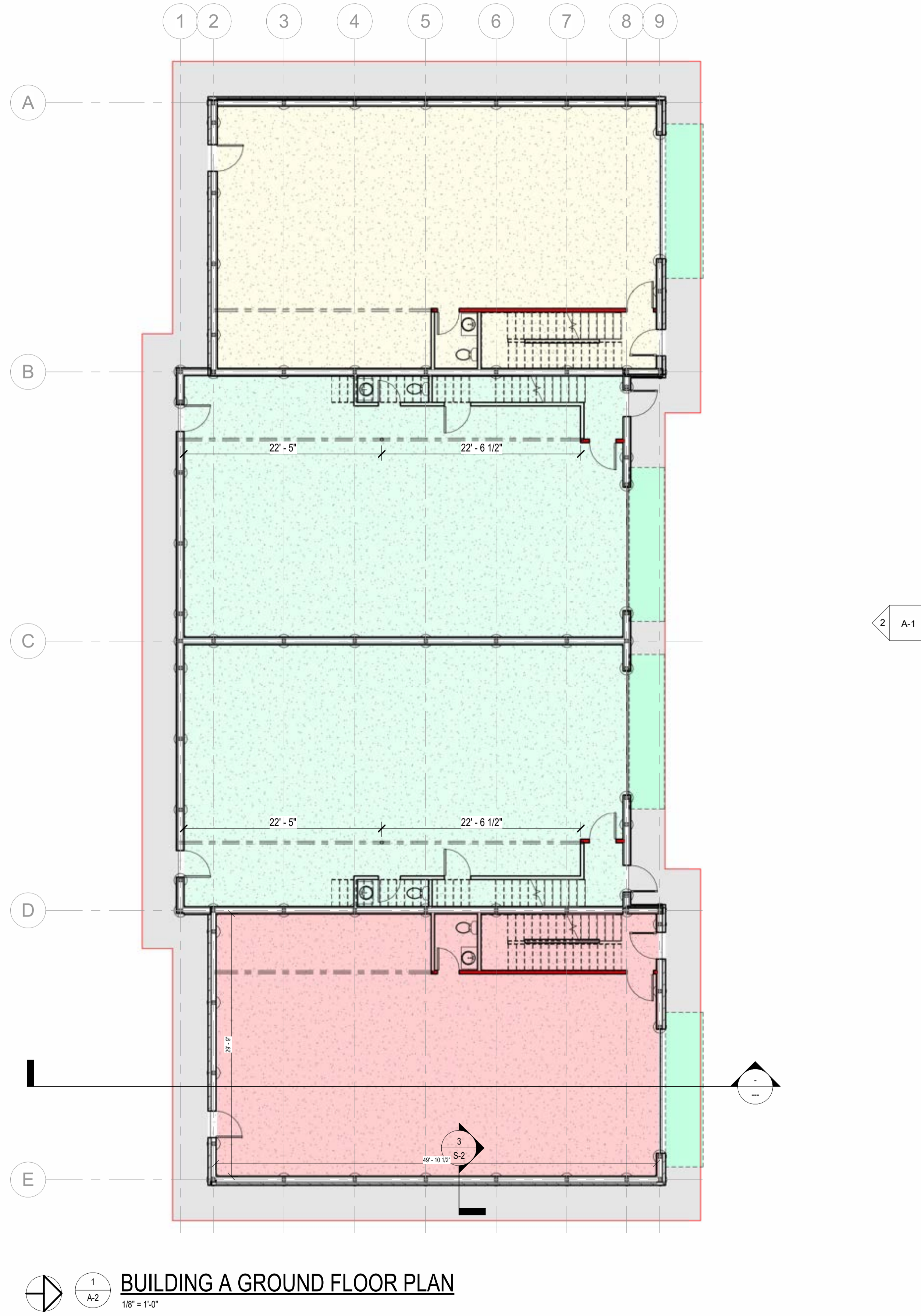

**BUILDING A GROUND FLOOR PLAN**  
1/8" = 1'-0"

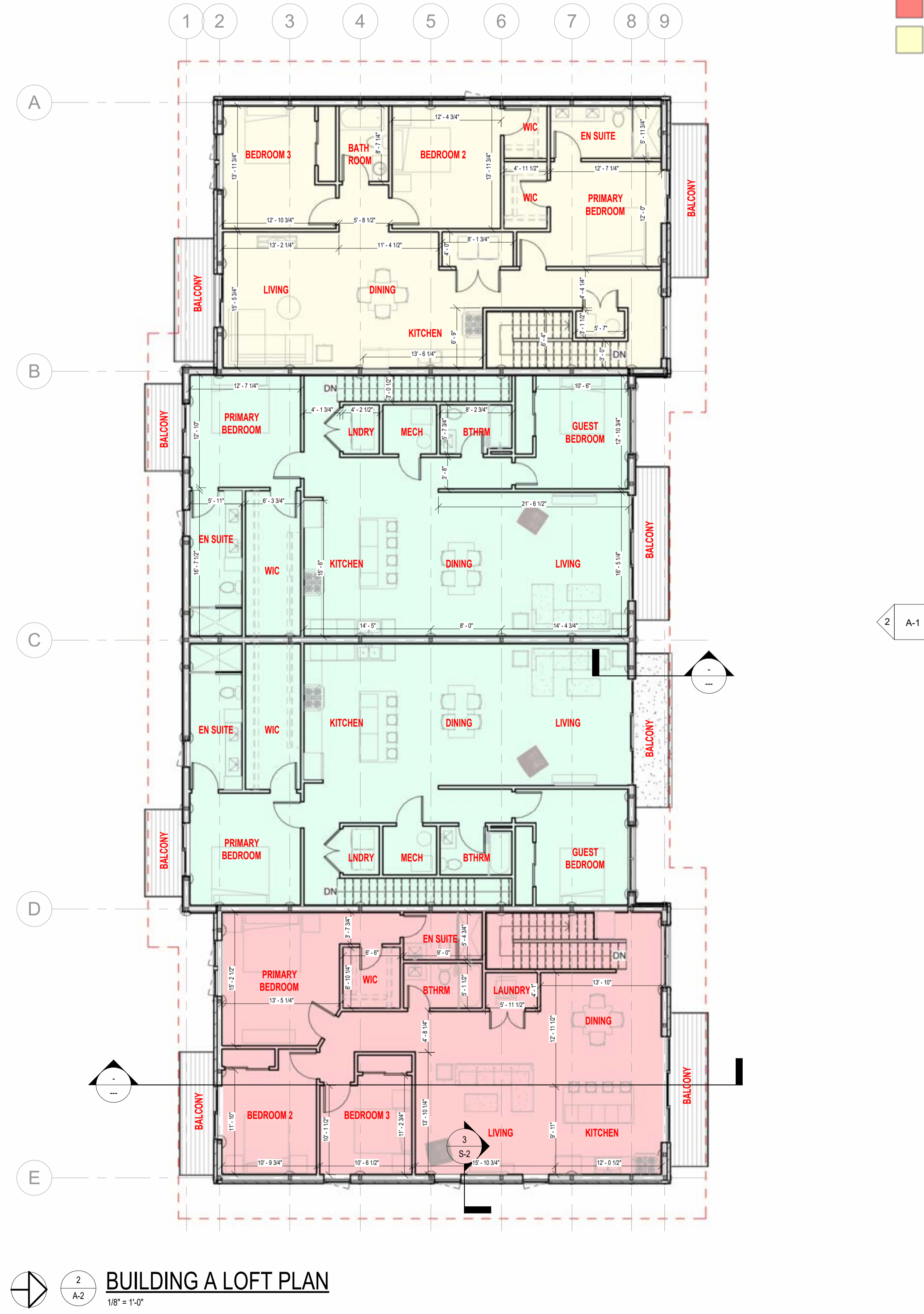

**BUILDING A LOFT PLAN**  
1/8" = 1'-0"

**UNIT TYPE KEY**

- 2-BEDROOM TYPE A
- 2-BEDROOM TYPE B
- 3-BEDROOM TYPE A
- 3-BEDROOM TYPE B



2 BUILDING G - FRONT ELEVATION  
A-3 3/32" = 1'-0"



3 BUILDING H - PARTIAL FRONT ELEVATION  
A-3 3/32" = 1'-0"



BUILDING G



BUILDING H

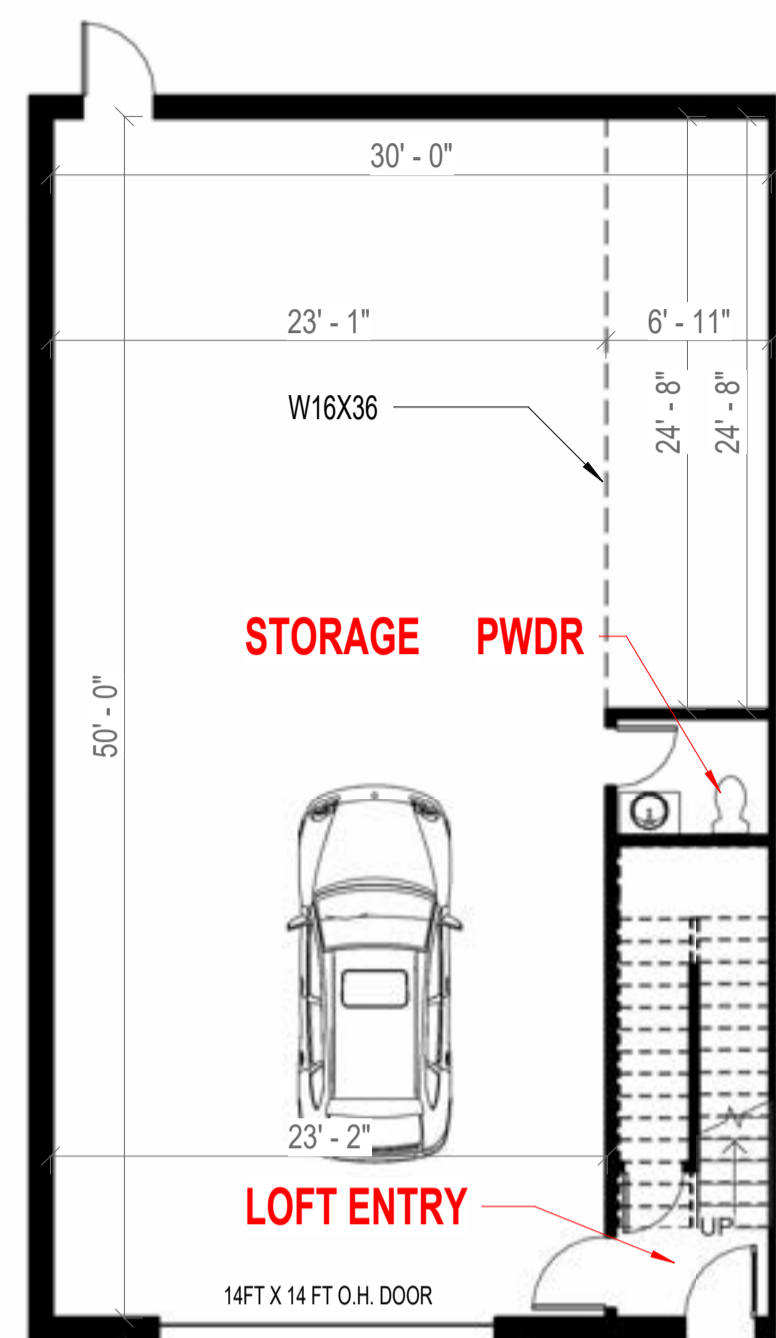
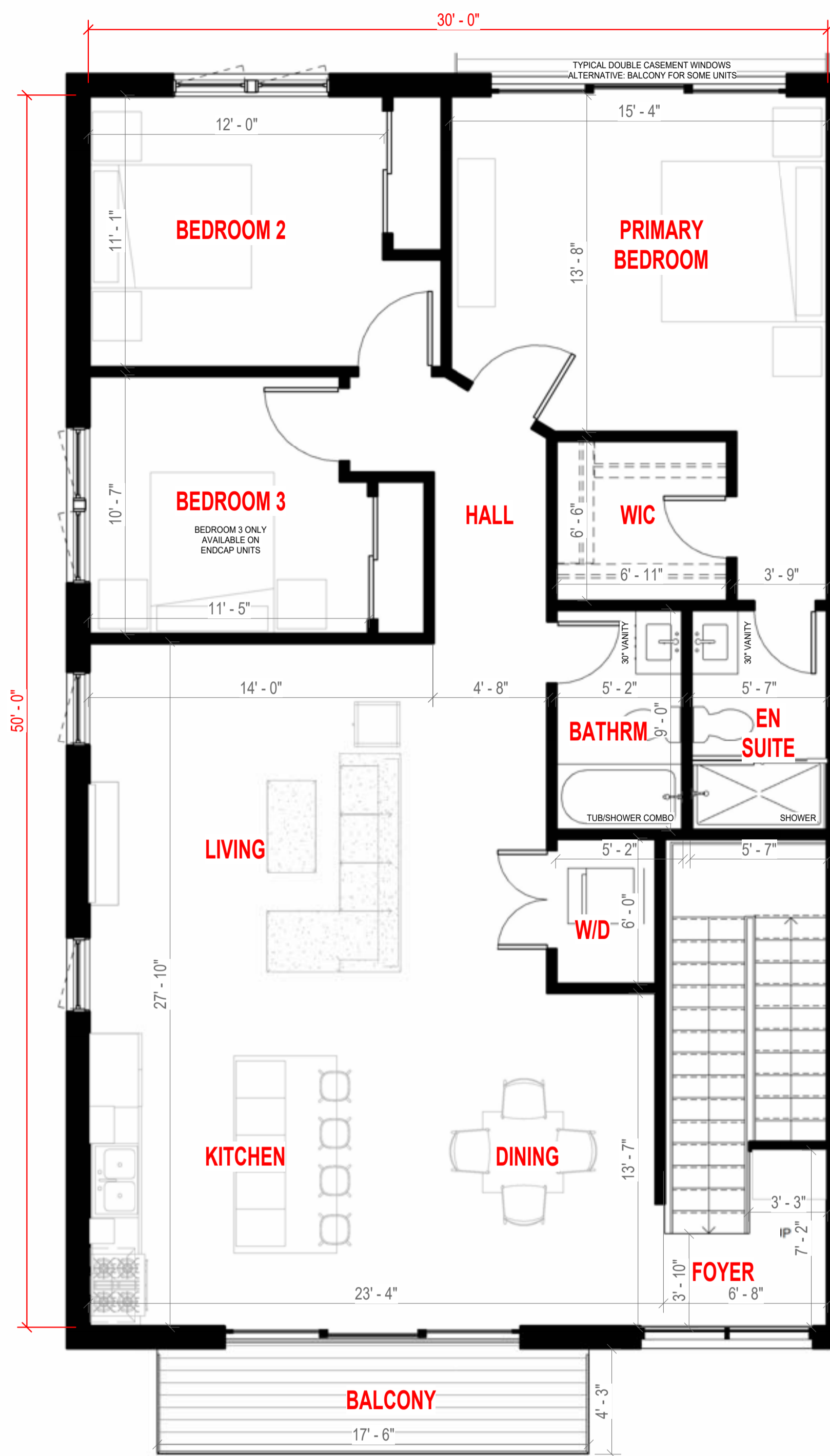

2  
A-4  
**3 BEDROOM STORAGE**  
1/8" = 1'-0"



FRONT ELEVATION



VIEW FROM FOYER



VIEW FROM KITCHEN

1  
A-4  
**3 BEDROOM LOFT**  
1/4" = 1'-0"



PRIMARY BEDROOM & EN SUITE



5844 RED ARROW HIGHWAY  
STEVENSVILLE, MICHIGAN 49127  
Phone: (269) 429-7000  
Fax: (269) 429-7888  
Email: ade@brooksrch.com

**BROOKS**  
ARCHITECTURAL

RED UNIT - 3 BEDROOM END CAP  
DRAWINGS FOR:  
**SOUTH HAVEN BARNDOMINIUMS**  
73rd Street South Haven MI

DRAWN BY: XX  
APPROVED BY: XX  
REVISIONS

PROJECT: 25-030C  
DATE: 8-4-2025

SHEET  
**A-4**  
OF XX

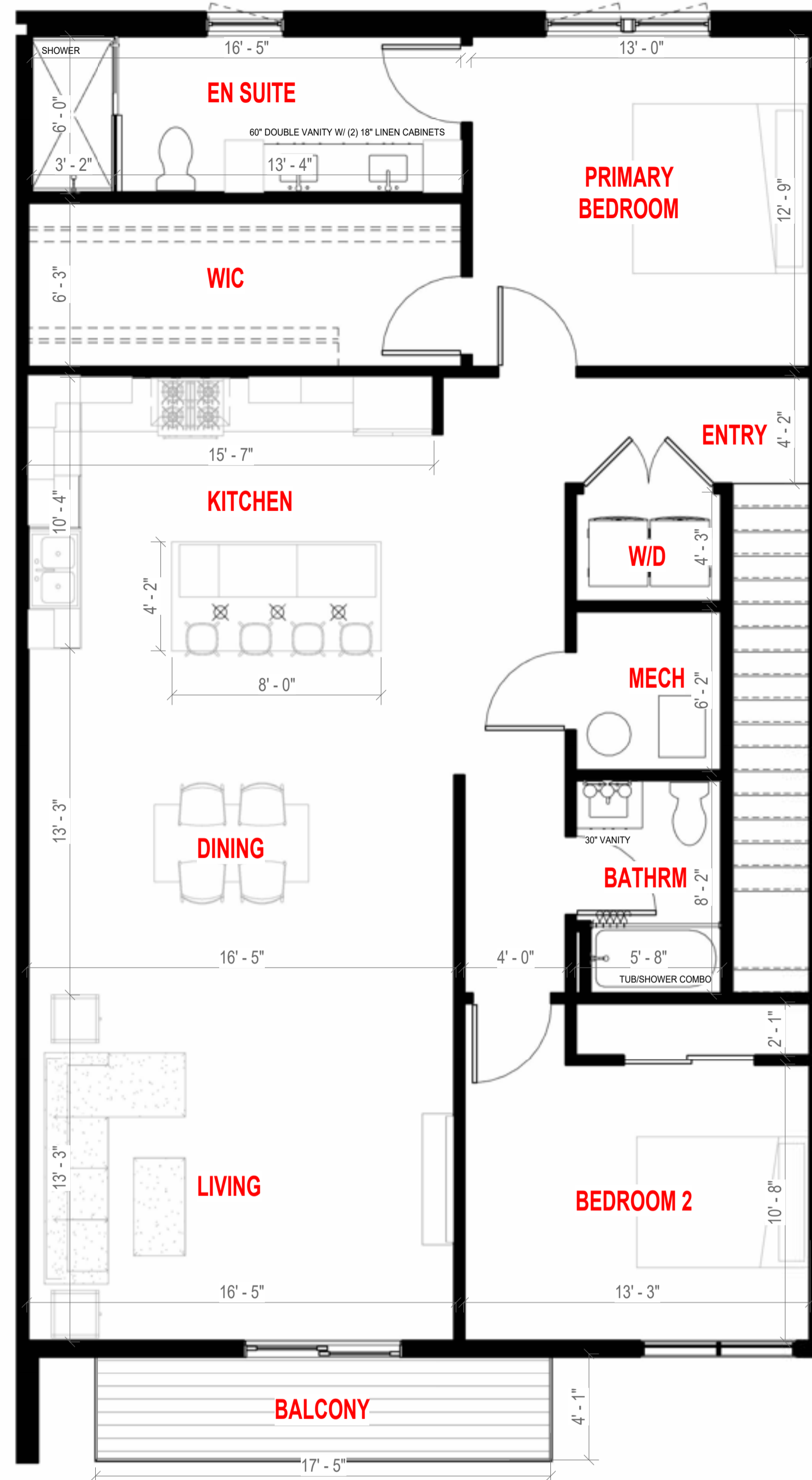

3  
A-5  
**2 BEDROOM LOFT**  
1/4" = 1'-0"

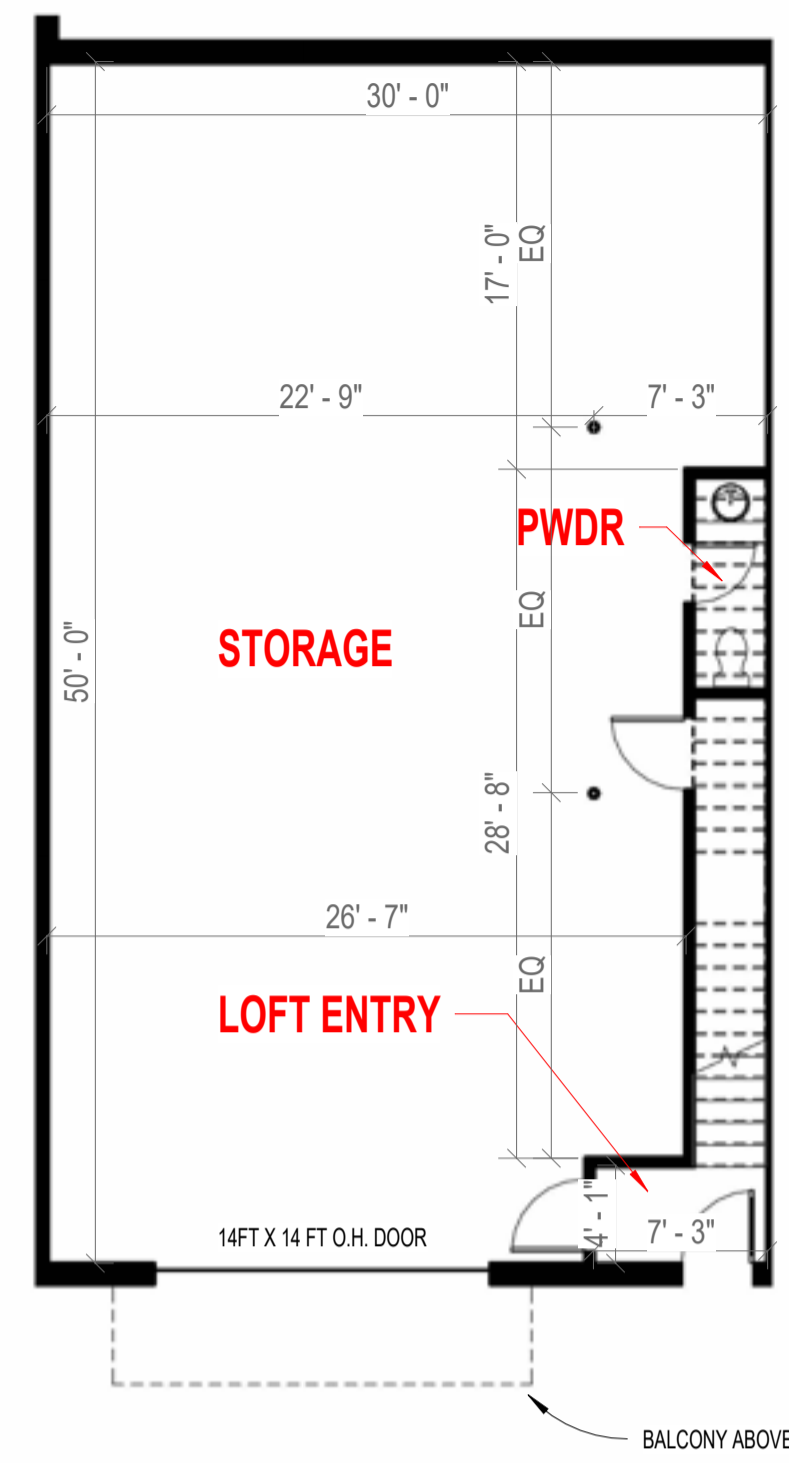

1  
A-5  
**2 BEDROOM STORAGE**  
1/8" = 1'-0"



**FRONT ELEVATION**



**VIEW FROM KITCHEN**

**VIEW FROM LIVING ROOM**



**EN SUITE BATHROOM**



**PRIMARY BEDROOM WITH WINDOW**



**BEDROOM 2**



**GUEST BATHROOM**

5844 RED ARROW HIGHWAY  
STEVENSVILLE, MICHIGAN 49127  
Phone: (269) 429-7000  
Fax: (269) 429-7888  
Email: ad@brooksrch.com  
© BROOKS ARCHITECTURAL INC. 2023

**BROOKS**  
ARCHITECTURAL

**GREEN UNIT - 2 BEDROOM (STRAIGHT STAIRS)**

DRAWINGS FOR:  
**SOUTH HAVEN BARNDOMINIUMS**  
73rd Street South Haven MI

DRAWN BY: XX  
APPROVED BY: XX  
REVISIONS

PROJECT: 25-030C  
DATE: 8-4-2025

SHEET  
**A-5**  
OF XX

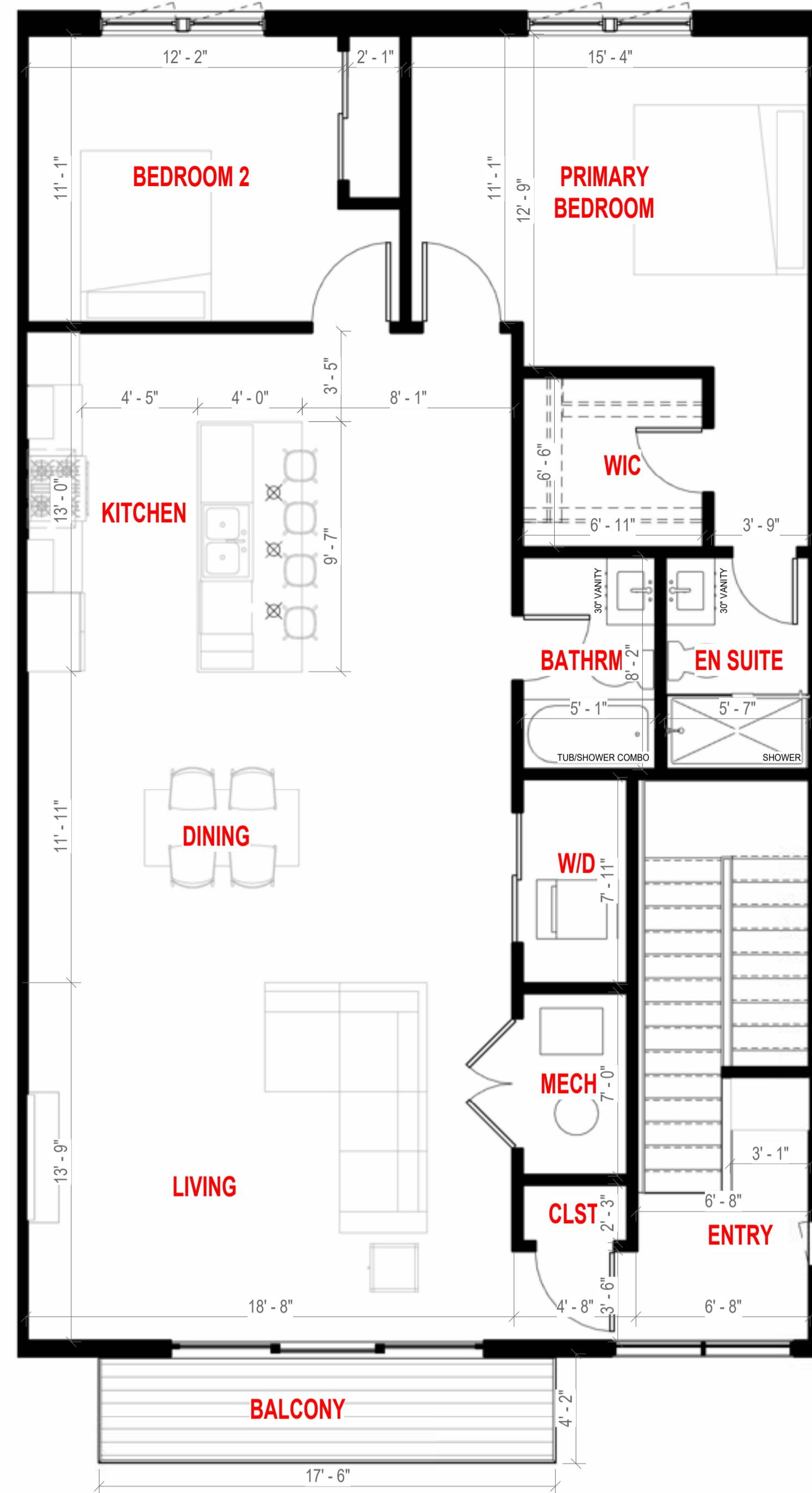

1 2 BEDROOM LOFT  
A-6 1/4" = 1'-0"



FRONT ELEVATION

UNIT C - 2 BEDROOM



VIEW FROM KITCHEN



VIEW FROM LIVING ROOM



EN SUITE BATHROOM



PRIMARY BEDROOM WITH BALCONY



BEDROOM 2



GUEST BATHROOM

5844 RED ARROW HIGHWAY  
STEVENSVILLE, MICHIGAN 49127  
Phone: (269) 429-7000  
Fax: (269) 429-7888  
Email: ade@brooksrch.com  
© BROOKS ARCHITECTURAL INC. 2023

**BROOKS**  
ARCHITECTURAL

GREY UNIT - 2 BEDROOM (SWITCHBACK STAIRS)

DRAWINGS FOR:  
**SOUTH HAVEN BARNDOMINIUMS**  
73rd Street South Haven MI

DRAWN BY: CV  
APPROVED BY: AA  
REVISIONS

PROJECT: 25-030C  
DATE: 8-4-2025

SHEET  
**A-6**  
OF XX

## SOUTH HAVEN AREA REGIONAL AIRPORT AUTHORITY MINUTES

March 18, 2026

Pursuant to Act 267 of 1976, as amended (Open Meetings Act), the Board Members of the South Haven Area Regional Airport Authority (SHARAA) met at the South Haven Area Regional Airport, 73020 C.R. 380, South Haven, Michigan on Wednesday, March 18, 2026.

Jon Woodhams Called a regular meeting of the South Haven Area Regional Airport Authority Board to order at 7:30 pm.

### BOARD MEMBERS PRESENT:

Jon Woodhams, Geneva Township, Chairman  
Mary Hosley, City of South Haven  
Mike Gillian, Covert Township  
Fred Bower, alternate for Covert Township  
Todd Jensen, South Haven Township  
Ross Woodhams, alternate for City of South Haven

### BOARD MEMBERS ABSENT:

Jim Sankofski, Casco Township  
Brent Nichols-City of South Haven, Vice Chairman  
Julian Allen, Covert Township

- I. **Agenda:** Mary Hosley motioned to approve the agenda for the March 18, 2026, Airport Board meeting. Todd Jensen seconded this motion. **All voted in favor. The motion to approve the agenda carries.**
  
- II. **Public Comments:** Mrs. Goldner inquired about the status of spring cleanup and restoration efforts related to recent obstruction removal projects. Staff confirmed that the contractors are expected to return sometime in the month of April to complete cleanup and restoration, and the airport will follow-up once a specific timeframe in April is known.

Mary Hosley motioned to approve the consent agenda, and Todd Jensen seconded this motion:

#### Consent Agenda:

- Expenses from:
- February 2026 totaling: \$107,369.43
  - Manager's report dated: March 18, 2026
  - Minutes of February 18, 2026

A roll call vote to approve the consent agenda was taken and **all voted in favor. The motion carries.**  
**YEA 6 / NA 0**

**III. Committee Reports: NONE**

**IV. Old Business:**

Airport Management provided a brief update on the FAA Airport Terminal Program (ATP) and requested board consideration for up to \$6,000 to conduct an Independent Fee Evaluation (IFE) with a qualified engineering firm.

After discussion on an IFE and other associated costs with the program, a motion was made by Mike Gillian and seconded by Fred Bower to not pursue the ATP program any further. A roll call vote was taken with the following results:

**YEA 2 / NA 4 The motion failed and no further action was taken.**

**V. New Business: NONE**

**VI. Member Comments: NONE**

Mike Gillian moved to adjourn the meeting and Mary Hosley seconded this motion. The meeting was adjourned at: 8:26pm

**SOUTH HAVEN AREA REGIONAL AIRPORT AUTHORITY**

Jonathon Woodhams, Chairman  
Brent Nichols, City of South Haven, Vice Chair  
Todd Jensen, South Haven Township  
Mary Hosley, City of South Haven  
Ross Woodhams, alternate for City of South Haven  
Mike Gillian, Covert Township

Julian Allen, Covert Township  
Jim Sankofski, Casco Township  
Fred Bower, alternate for Covert  
Township  
Nancy Kelley, Treasurer  
Dan Sanborn, Secretary

# Michigan Township Services - Allegan, Inc.

111 Grand Street  
(269) 673-3239 fax: (269)673-9583

## Permits Issued For SOUTH HAVEN TOWNSHIP

### Building

Date	Permit #	Site Address	Construction Cost	Permit Cost	Owner	Type Of Construction
3/4/2026	SHB26007	15222 76th St	\$18,719.00	\$197.00	Mazurkiewicz	Replace 6 Windows
3/5/2026	SHB26008	72634 16th Ave	\$325,000.00	\$1,115.00	Graver Realty LLC	New Res w/ Att Garage
3/6/2026	SHB26009	70802 8th Ave	\$9,000.00	\$130.00	LeVesque	Encapsulate Crawl Space
3/11/2026	SHB26010	76757 Wood Crest Ct	\$1,094,367.00	\$4,295.00	Wood Crest Cottag	New Res w/ Att Garage
3/18/2026	SHB26011	70854 8th Ave	\$11,000.00	\$173.00	Yancy	Above Ground Pool
3/19/2026	SHB26012	17367 Bluestar Hwy	\$8,900.00	\$129.00	Mueller	Re-Roof
3/20/2026	SHB26013	19310 Blue Star Hwy	\$25,000.00	\$215.00	Gilbert	Garage Addition
3/20/2026	SHB26014	71751 C. R. 388	\$8,000,000.00	\$16,140.00	Horizon South Have	Hotel
3/26/2026	SHB26015	71538 M-43 Hwy	\$12,000.00	\$176.00	C & R's Out on a Li	ID Sign
3/27/2026	SHB26016	12412 76th St	\$65,000.00	\$335.00	Steven Ashby	Inground Pool & Deck
<b>Building Totals</b>			<b>\$9,568,986.00</b>	<b>\$22,905.00</b>		

### Electrical

Date	Permit #	Site Address	Construction Cost	Permit Cost	Owner	Type Of Construction
3/5/2026	SHE26014	10336 Blue Star Hwy		\$299.00	10336 Blue Star Hw	Kitchen/Addition
3/5/2026	SHE26015	75746 14th Ave		\$116.00	Thompson	Accessory Building
3/24/2026	SHE26017	76757 Wood Crest Ct		\$110.00	Cottage Home	
3/24/2026	SHE26018	70458 C. R. 384		\$316.00	Munn	Barndominium
3/24/2026	SHE26019	70802 8th Ave		\$110.00	LeVesque	Encapsulate Crawl Space
3/27/2026	SHE26020	70969 8th Ave		\$115.00	Castillo-Wagger	
3/26/2026	SHE26021	71538 M-43 Hwy		\$105.00	C & R's Out on a Li	ID Sign
<b>Electrical Totals</b>				<b>\$1,471.00</b>		

### Mechanical

Date	Permit #	Site Address	Construction Cost	Permit Cost	Owner	Type Of Construction
3/11/2026	SHM26009	09794 76th St		\$130.00	Hawkins	
3/5/2026	SHM26011	76443 11th Ave		\$115.00	Olsen	
3/11/2026	SHM26013	09404 73rd St		\$115.00	Dopp	
3/11/2026	SHM26014	11566 76th St		\$115.00	Leavitt	
3/11/2026	SHM26015	70854 8th Ave		\$115.00	Yancy	
3/6/2026	SHM26016	76589 Evergreen Bluff		\$115.00	Knytch	
3/11/2026	SHM26017	76717 14th Ave		\$130.00	Williams	
3/12/2026	SHM26018	71355 C. R. 388		\$243.00	Matthew Barker	Rmdl Warehouse/Office
3/17/2026	SHM26019	77130 Marwood Dr		\$290.00	Miller	New Res w/ Att Garage
3/17/2026	SHM26020	23289 76th St		\$140.00	Gorske	
3/17/2026	SHM26021	77336 Summers Gate Circle		\$130.00	Mack	
3/24/2026	SHM26022	10864 M-140 Hwy		\$115.00	Hanson	
3/27/2026	SHM26023	71830 16th Ave		\$115.00	Newton	
3/27/2026	SHM26024	10336 Blue Star Hwy		\$189.00	10336 Blue Star Hw	Kitchen/Addition
<b>Mechanical Totals</b>				<b>\$2,057.00</b>		
<b>Mechanical Totals</b>			<b>\$9,568,986.00</b>	<b>\$26,133.00</b>	<b>\$2,613.30</b>	

**SOUTH HAVEN CHARTER TOWNSHIP  
PLANNING COMMISSION  
MINUTES**

Wednesday, April 1, 2026

Draft

**Special Zoning Ordinance Workshop 5:00pm**

**Call to Order: 5:00 PM**

**Public Comment – none**

**Workshop – Site Plan review and Signs**

**Public Comment / Commissioner Comment – none**

**Adjourn 6:45PM**

**Regular meeting**

**1) Call to Order: 7:00 PM**

**2) Role Call:**

Tippman - present  
Kiry – absent, excused  
Odland – absent, excused  
Meyer – absent, excused  
Poole – present  
Dibble – present  
Nicol – present

Zoning Administrator: Tasha Smalley  
Audience: Brad Kotrba, Williams and Works  
Township residents

**3) Approval of the Agenda**

Tippman requested to move Staff Reports after New Business and then Unfinished Business. Motion by Poole to approve the agenda with changes, second by Dibble, 4-0 yes, motion passed.

**4) Approval of the Minutes**

Motion by Dibble to approve the minutes as presented, of March 4, 2026, second by Poole, 4-0, yes motion passed.

**5) Public Comment non-agenda items** - Natalie Escandon, The Hostel on M-43; questions regarding ordinances for camping. Smalley briefly went over the current ordinance requirements and the draft ordinance. Smalley will meet with them at a later time and go over all the options. She also asked who to contact for speed limit; she was directed to call the State Police; and who to contact about the drainage after the internet company; she was directed to contact MDOT.

**6) Communications / Correspondence** - none

**7) Public Hearing** - none

**8) New Business** – none

**9) Staff & Subcommittee report**

- a. Board report – Poole – working with Habitat for Humanity on a housing project Township property on Baseline and Blue Star Hwy; official letter sent to Lansing in support MTA opposition of the state taking over local zoning issues; Land div act was amended to allow more division for parcels 10acres, the Board kicked back to PC to gather more information before amending the Township Land Division ordinance.
- b. Zoning Board of Appeals – Tippman – no meeting
- c. Zoning report – Smalley – Site plan for May meeting, Corwell building on Phoenix; info for land div act amendments

**10) Unfinished Business** – Continue zoning ordinance update, Brad Kotrba, Williams and Works Draft Site Plan Review, Signs, Off-Street Parking, Site Lighting, Landscaping. All the draft sections have been reviewed by the PC. The full draft with few changes/corrections will be provided to review and finish it up.

**11) Commissioner Comments and Public Comment** Tippman and Trustee Dave Wiatrowski went SW Michigan Coastal Leadership Academy Workshop, Adaption Strategies for Coastal Hazards on March 31 in Bridgeman.

**12) Adjournment**

at 8:35 pm

*Respectfully Submitted by:*

*Tasha Smalley*

*Zoning Administrator/Recording Secretary*



# Van Buren Conservation District

## April 2026 Program Update

When it rains, it pours, and it is April! We're excited to be outdoors a lot this month and all over the county with various projects and events.

**Grants Received** - The Michigan Department of Natural Resources awarded both grants we applied for last fall for invasive species work. We received the highest amount of grant funds for these projects of all of the applications awarded in the state. With these funds, we will provide education; survey for high priority, high impact invasive species; and train more people to find and manage invasive species.

**Seasonal Employees Hired** - We have hired three seasonal employees who will start mid-May to work on invasive species projects and recycling projects with the rest of the team. We are looking forward to making great impacts and providing services with these folks this summer.

**Tree Sale** - Leftover seedlings will be available for sale April 10 and 11 in Paw Paw (VBCD office) and South Haven (Liberty Hyde Bailey Museum). Adding these seedlings to your property encourages large scale pollinator and wildlife habitat building and adds to our community's beauty. Profits from the sale go back into our conservation efforts and programs. Shop the sale at [VanBurenCD.org/Shop](http://VanBurenCD.org/Shop)

**VBCD Newsletter** - Our subscriber newsletter is now available on our website at [VanBurenCD.org/News](http://VanBurenCD.org/News) and will be attached to these update emails going forward. We hope this helps you stay connected. As always, reach out anytime with questions, ideas, and concerns.

*Emilly Hickmott*

Emilly Hickmott, Executive Director

### **Upcoming Events** (details available on [our website](#))

- Tree Sale Order Pickup & Leftover Sale | Friday, April 10 & Saturday April, 11 | [VanBurenCD.org/shop](http://VanBurenCD.org/shop)
- VBCD Board Meeting | April 22 | [VanBurenCD.org/About](http://VanBurenCD.org/About)
- Electronics Recycling Event - Porter Township | Tuesday, May 5 | <https://vanburencd.org/van-buren-county-recycling-collections/>
- Electronics Transfer Station Host Drop-off - Decatur | Saturday, May 9 and Saturday, May 16 | <https://vanburencd.org/van-buren-county-recycling-collections/>
- Memorial Day - office closed | Monday, May 25



# Van Buren Conservation District

## April 2026 Program Update

- VBCD Board Meeting | Wednesday, May 27 | [VanBurenCD.org/About](https://VanBurenCD.org/About)
- VBCD at the Decatur Night Market | Friday, May 29
- VBCD Annual Meeting & Director Election | July 17 | details to be announced

### Program Updates

**Resource Recovery & Recycling** (*Kalli Marshall, Jacob Diljak*) – Five communities have worked with us to make their drop-off centers a place that you can bring foam in for recycling year-round. You can learn more about where and how by checking out the announcement at [VanBurenCD.org/foam-recycling](https://VanBurenCD.org/foam-recycling) Our 2026 collection events have been announced. This year's electronic recycling opportunities have been changed to make it easier to keep those valuable materials in the economy. [VanBurenCD.org/van-buren-county-recycling-collections](https://VanBurenCD.org/van-buren-county-recycling-collections)

**Outreach** (*Jacob Diljak*) – Jacob worked hard to wrap up his tree sale and Food, Farm, & Fun Guide assignments. The guides will be distributed in April. He also prepared training materials and notes for the team before his last day mid-March. We wish Jacob well on his next adventure!

**Agriculture & Water Quality Team** (*Erin Fuller and Colleen Forestieri*) – In February, Colleen Forestieri attended the Underground Innovations Conference in Frankenmuth, MI. Colleen was invited to moderate a farmer forum and panel discussion at the conference, discussing Sustainable Agriculture Research and Education (SARE) projects. In March, the team held the Farming for the Future Conference and connected with over 100 attendees about conservation practices.

**Invasive Species SWxSW Corner CISMA Team** (*Alex Florian and Jena Johnson*) – The CISMA team hosted our Annual Meeting, took the first major steps towards hiring our 2026 strike team crew, and attended the MISC Annual Meeting in Gaylord, MI. The CISMA team steadily chipped away at multiple projects with upcoming deadlines, and worked to stay on top of public inquiries. In terms of field work, the team stayed busy doing contracting work for Chikaming Open Lands, and began GLRI shrub management with the help of Van Buren Conservation District conservation technician, Gabe Francisco.

**Conservation Technical Assistance Program: MAEAP and Regenerative Agriculture Programs** (*Kyle Mead*) – The specialist continues to plug away at farm visits for assessments and verifications. As days get longer and warmer this gets easier. Kyle continues to assist the Natural Resource Conservation Service (NRCS) as they need, and is helping to put the final touches on



# Van Buren Conservation District

## April 2026 Program Update

VBCD's annual Farming for the Future Event as well the Regional Envirothon competition which both happened in March.

**Natural Resource Technical Assistance** (*Gabriel Francisco*) - This month has been dedicated to many national NRCS training, and assisting the CISMA team performing GLRI Shrub Management work. NRCS trainings for the standard Farm Bill Roll out that happens each year in February as well as training in both providing assistance to USDA Organic producers and Soil Health training regarding the new RPP (Regenerative Pilot Program) offered through the Department of Agriculture this year.

**Forestry Assistance Program** (*Benjamin Savoie, Barry Conservation District*) - Ben is working across nine counties, including Van Buren County, supporting our forests. Working with landowners, Ben works in the Qualified Forest Program to save landowners money and strengthen forest health.